

# Meisterstücke Masterpieces

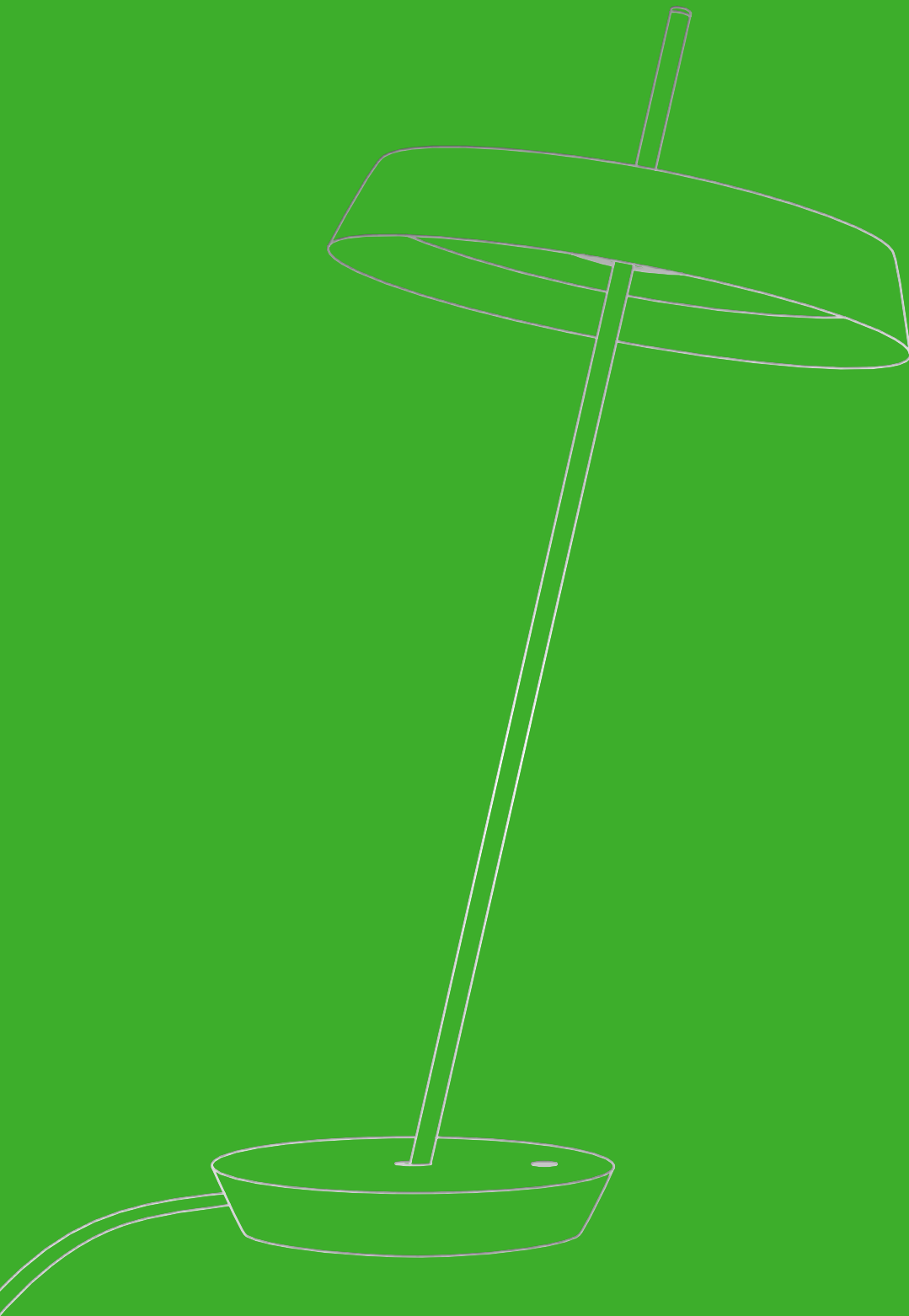



Made in Brandenburg

# German »Gemütlichkeit«

Überblick 4  
*Overview*

Material, Oberflächen, Farben 22  
*Material, surfaces, colors*

Tisch- und Stehleuchten 26  
*Table and floor lamps*

Pendelleuchten 84  
*Pendant lights*

Wand- und Deckenleuchten 146  
*Wall and ceiling lights*

Mit hochwertigen Objekten für den Wohnbereich begann die Geschichte von mawa vor über 40 Jahren. Eigene Entwürfe und Kooperationen mit externen Designer:innen brachten schon damals Produktideen hervor, die Vorreiter ihrer Zeit waren.

Dekorative Leuchten waren seit jeher Teil der Kollektion. Das änderte sich auch nicht, als sich der Firmenfokus zum Jahrhundertwechsel gänzlich auf Beleuchtung verschob und technisches Licht für Handel und Museum zunehmend in den Vordergrund rückte.

Noch heute legt mawa viel Wert auf dekorative Modelle, die Privathäuser, denkmalgeschützte Gebäude, Museen oder Hotels beleuchten. Mit Gespür und höchstem Anspruch an Qualität lässt mawa vergangenes Handwerk aufleben, bedient den Minimalismus unserer Zeit und ermöglicht dazwischen viel Raum für Individualität.

The history of mawa began over 40 years ago with high-quality objects for the living area. Even then, own designs and collaborations with external designers gave birth to product ideas that were pioneers of their time.

Decorative lamps have always been part of the program. That didn't change when the company's focus shifted entirely to lighting at the turn of the century and technical lighting for retail and museums increasingly came to the fore.

Even today, mawa attaches great importance to decorative models that adorn private houses, listed buildings, museums or hotels. With intuition and the highest quality standards, mawa revives past craft, serves the minimalism of our time and leaves plenty of room for individuality in between.

Technische Informationen zu den Leuchten finden Sie auf der mawa Website.  
Technical information about the luminaires can be found on the mawa website.



# Überblick Overview

## Tisch- und Stehleuchten Table and floor lamps



**bologna**  
> 30



**giro  
giro-Edition**  
> 34



**heron**  
> 38

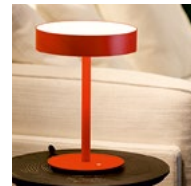

**tadeo 1**  
> 40

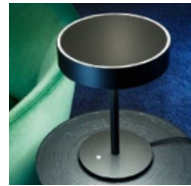

**tadeo 2**  
> 44



**polly**  
> 48



**stuttgart 2**  
> 52

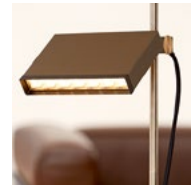

**fbl-sl**  
> 54

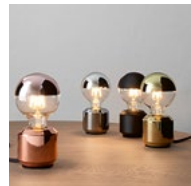

**oskar  
oskar dim**  
> 58



**schliephacke**  
> 62

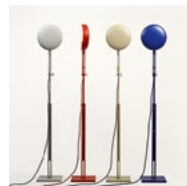

**schliephacke-Edition**  
> 64

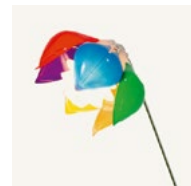

**ssymmank**  
> 66

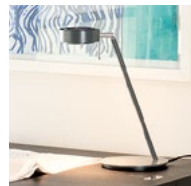

**pure mini**  
> 70



**pure 1**  
> 72

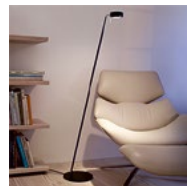

**pure 2**  
> 76



**parkett wi4-bod-2e-hb**  
> 80



**druff wi4-reg-2e-hb**  
> 82

## Pendelleuchten Pendant lights



**porto**  
> 90



**bergamo**  
> 96



**granada**  
> 100



**bologna**  
> 102



**pisa**  
> 106



**venezia**  
> 108

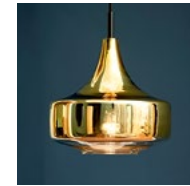

**vesuvio**  
> 110



**d28**  
> 120



**glaskugelleuchte**  
> 122



**glaskugelleuchte LED**  
> 126

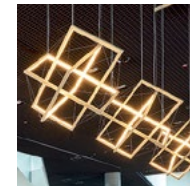

**goldener schnitt 1**  
> 130



**goldener schnitt 2**  
> 132

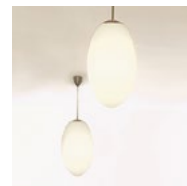

**havanna**  
> 134

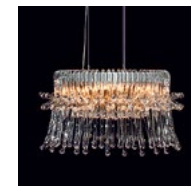

**madrid rund**  
> 136

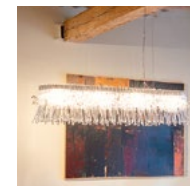

**madrid oval**  
> 138



**mondello**  
> 140



**ssymmank 1p / 4p**  
> 142

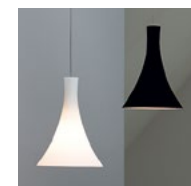

**tokyo**  
> 144



# Überblick Overview

## Wand- und Deckenleuchten Wall and ceiling lights

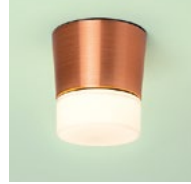

jo  
jo IP44  
> 150

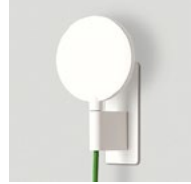

maggy 1  
> 152



maggy 3  
> 154



maggy 4  
> 156



tesechzehn  
> 158



eintopf  
eintopf KPM-Edition  
> 160



eintopf einbau  
> 162

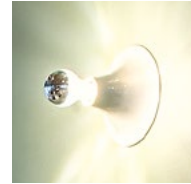

etna  
etna KPM-Edition  
> 166



linestra 7/7b  
linestra 8  
> 168



stuttgart eb  
stuttgart ab  
> 170

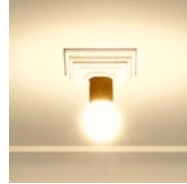

paul  
> 172



paula  
paula KPM-Edition  
> 174



britz 1  
britz 2  
> 176



tegel 2/6/7  
> 178



111er  
> 180

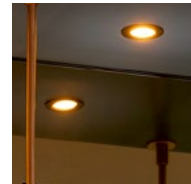

d28-eb-r  
d28-eb-rs  
> 182



warnemünde 23  
warnemünde 33/63  
> 184



wi4-eb-1r-dl-IP44  
> 186



wi4-ab-1r-dl-IP54  
> 188

»Unserem Kerngeschäft, den technischen Leuchtensystemen, die mawa produziert, sieht man eine Beeinflussung der klassischen Moderne an. Dabei verfolgen wir bei Neuentwicklungen immer ein wichtiges Ziel: Nachhaltigkeit, auch im Design. Das heißt, unsere Produkte müssen durabel sein, gerne auch moderesistent, nach Jahren des Gebrauchs technisch und optisch funktionieren – übertrieben ausgedrückt: auch in Würde altern. Das ist, denke ich, unser größter Beitrag zur Nachhaltigkeit.«

Martin Wallroth, Gründer

*“You can see an influence of the classical modernism on our core business, the technical lighting systems that mawa produces. Thereby, we always pursue an important goal with new developments: sustainability, also in design. That means our products must be durable, preferably also resistant to trends, functioning technically and optically after years of use. In exaggerated terms: age with dignity. I think this is our greatest contribution to sustainability.”*

Martin Wallroth, founder







created and manufactured  
in Brandenburg





# mawa hat Karakter

*mawa has character*





präzise und technisch  
*precise and technical*



ästhetisch und visionär  
*aesthetic and visionary*





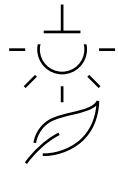

**nachhaltig** – Zukunftskompatibilität und Nachhaltigkeit sind mawa besonders wichtig. Bei der Entwicklung von Leuchten und Lichtsystemen folgt mawa keinen modischen Trends, sondern setzt auf Entwürfe, die Langlebigkeit versprechen.

*sustainable* – Future compatibility and sustainability are particularly important to mawa. In the development of luminaires and lighting systems, mawa does not follow the latest trends, but focuses on long-lasting designs.



**präzise und technisch** – Jede Leuchte von mawa ist ein Original, das am eigenen Standort Seddiner See produziert wird. Mit »Produktion« ist die gesamte Entwicklung gemeint, die mehrere Jahre dauern kann. Design, Technik und Herstellung sind hier allesamt in »Sichtweite« und einem ständigen Austausch.

*precise and technical* – Every luminaire from mawa is an original, produced at the company's production site in Neuseddin. "Production" means the entire development process, which can take up to several years. Design, technology and production are all here in "sight" and in continuous exchange.

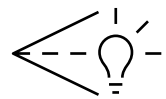

**ästhetisch und visionär** – Gestalterische und technische Innovationen bieten uns im Umgang mit Licht stets neue Möglichkeiten, unsere Lebenswelten zu bereichern. mawas hoher Anspruch zeigt sich in der hervorragenden Verarbeitung, in technischer Raffinesse und in den eigenen Patenten. Nicht zuletzt ist mawa bekannt für exzellente Oberflächen-gestaltung, die Fachleute schon mal für nasslackiert hielten.

*aesthetic and visionary* – Design and technical innovations constantly offer us new possibilities in dealing with light to enrich our living worlds. mawa's high standards are reflected in the outstanding workmanship, in technical sophistication and in its own patents. Last but not least, mawa is known for excellent surface design, which experts sometimes mistake for wet paint.

rechts: mawa die Hightech-Manufaktur,  
Standort Seddiner See  
right: mawa the high tech manufactory,  
location Seddiner See

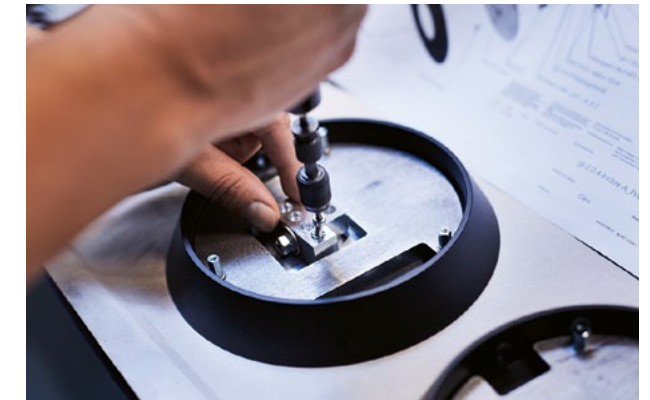
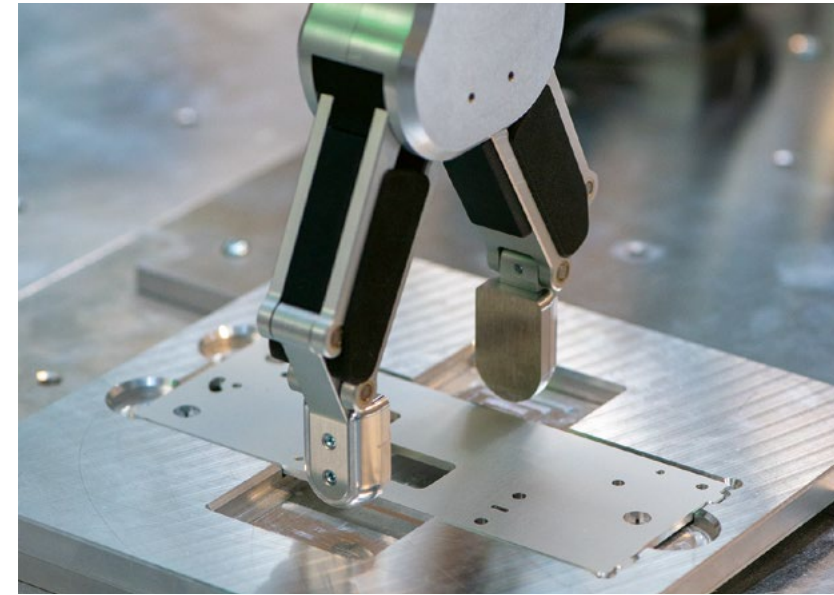

Fotos: Leon Kopplow, WFB, mawa







# Material, Oberflächen, Farben

## Material, surfaces, colors

Leuchten von mawa sind Handschmeichler. Die äußerst feine und besonders glatte Pulverbeschichtung, standardmäßig in Schwarz oder Weiß, überzeugt Finger- spitzen und Augen gleichermaßen. Allerdings stellt sie hohe Ansprüche an die Beschaffenheit des Rohmaterials, die mawa mit präziser CNC-Technik und topausgebildeten Metallverarbeitenden gewissenhaft erfüllt.

Dieses Beschichtungsverfahren und die langjährige Zusammenarbeit mit zuverlässigen Partner:innen ermöglichen die Umsetzung normierter Farbsysteme und speziell entwickelter Effekt-Pulver. Auf diese Weise lassen sich Bronze nachbilden und eloxierte Oberflächen überzeugend imitieren. Oberflächen in »mawa Eloxa« sind im Vergleich zum Original weniger empfindlich, homogen in Farbe und wiederholgenau im Erscheinungsbild.

Dem Zeitgeist zu entsprechen und sich doch frei von Moden zu bewegen, bedeutet für mawa farbige Oberflächen anzubieten, die Leuchten in trendresistente Statements verwandeln.

Anlässlich des einhundertjährigen Bauhaus-Jubiläums 2019 haben farbtiefes Grau, Beige, Rot und Blau Einzug gehalten. In Verbindung mit gebürsteten Messing-Applikationen lassen sie Klassiker wie die Stehleuchte schliephacke in frischem Glanz erstrahlen. Mit Hochglanz überzeugen Einzelkomponenten und dekorative Glasschirme in Chrom, Messing oder Kupfer-Optik. Ob galvanisch veredelt oder professionell bedampft, sie verleihen zeitloser Formensprache das gewisse Etwas.

Auf besonderen Wunsch wird gänzlich auf Beschichtung verzichtet, sodass Bearbeitungsspuren oder gezieltes Schliffbild die technische Anmutung dominieren.

Luminaires from mawa are tactual charmers. The extremely fine and particularly smooth powder coating, as standard in black or white, impresses fingertips and eyes alike. However, it makes high demands on the quality of the raw material, which mawa conscientiously meets with precise CNC technology and highly trained metalworkers.

This coating process and the long-term cooperation with reliable partners enable the implementation of standardized color systems and specially developed effect powders. In this way, bronze can be reproduced and anodized surfaces can be convincingly imitated. Surfaces in "mawa Eloxa" are less sensitive compared to the original, homogeneous in color and repeatable in appearance.

For mawa, being up-to-date and yet free of the latest trends means offering colored surfaces that transform luminaires into trend-resistant statements.

On the occasion of the one hundredth anniversary of the Bauhaus in 2019, deep grey, beige, red and blue have made their way into the portfolio. Together with brushed brass applications, they let classics such as the floor lamp schliephacke shine in a fresh splendor. Individual components and decorative glass shades in chrome, brass or copper look impress with high gloss. Regardless of whether they are electroplated or professionally steamed, they stand for timeless design and a certain je ne sais quoi.

On special request, no coating is used at all, so that traces of processing or specific grinding patterns dominate the technical appearance.

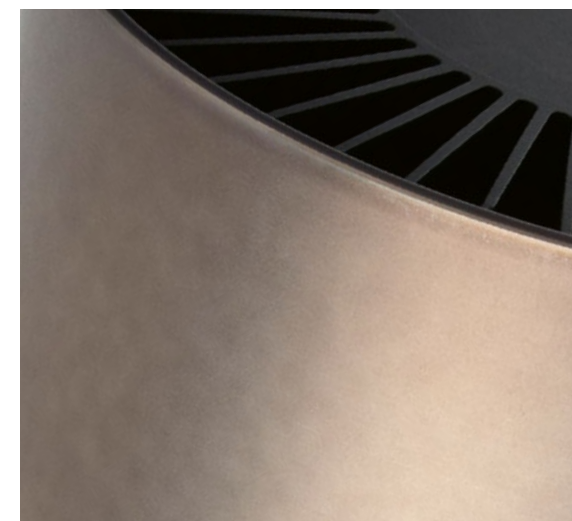
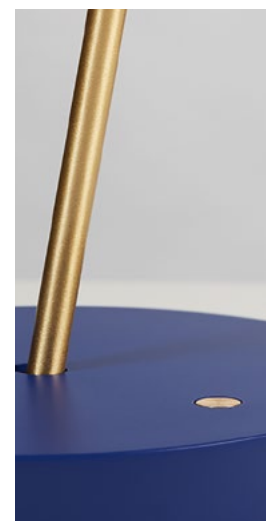

Fotos: Leon Kopplow, Martin Tervoort, mawa









# Material, Oberflächen, Farben

## Material, surfaces, colors

### Pulverbeschichtungen Powder coatings













-  weiß matt (RAL 9016) white matt (RAL 9016)
-  schwarz matt (RAL 9005) black matt (RAL 9005)
-  sandsilber sand silver
-  beige beige
-  grau grey
-  rot red
-  blau blue
-  grünblau matt (RAL 5001) green blue matt (RAL 5001)
-  zementgrau Feinstruktur (RAL 7033)  
cement grey fine structure (RAL 7033)
-  ozeanblau Feinstruktur (RAL 5020)  
ocean blue fine structure (RAL 5020)
-  bordeauxviolet Feinstruktur (RAL 4004)  
bordeaux violet fine structure (RAL 4004)
-  rapsgelb matt (RAL 1021) colza yellow matt (RAL 1021)
-  leuchtorange (RAL 2005) luminous orange (RAL 2005)
-  grau metallic (DB 702) grey metallic (DB 702)
-  industrial industrial
-  bronze bronze
-  dunkelbronze dark bronze

### Materialien Materials







-  Aluminium aluminum
-  Edelstahl V4A stainless steel V4A
-  Messing brass
-  Bronze bronze

Oder doch eine andere Farbe? Die Farbvielfalt ist unbegrenzt. Auf Wunsch sind bei mawa alle RAL-Farben, Pantone® und NCS möglich.

### Oberflächenveredelungen Surface finishings

-  chrom chrome
-  chrom gebürstet chrome brushed
-  messing brass
-  messing gebürstet brass brushed
-  messing brüniert brass burnished
-  kupfer copper
-  kupfer gebürstet copper brushed
-  vernickelt matt nickel plated matt
-  aluminium geschliffen eloxiert aluminum ground anodized
-  edelstahl matt gebürstet stainless steel matt brushed
-  blattvergoldet gold leaf
-  blattversilbert silver leaf

### Glasvarianten Glass versions

-  opal weiß matt opal white matt
-  klar glänzend clear glossy
-  rauch glänzend smoke glossy
-  opal anthrazit matt opal anthracite matt
  
-  chrom-Verlauf / klar glänzend  
chrome gradient / clear glossy
-  gold-Verlauf / klar glänzend  
gold gradient / clear glossy
-  roségold-Verlauf / klar glänzend  
rosegold gradient / clear glossy

Or a different color after all? The variety of colors is unlimited. Upon request, all RAL colors, Pantone® and NCS are possible at mawa.



Foto: Leon Kopplow

# mawa ist Pionier mawa is a pioneer

mawas Designverständnis und Innovationsanspruch zeigen sich in der exzellenten Verarbeitung der Produkte, in technischer Raffinesse und in den eigenen Patenten. Alle Produkte sind Originale, die von der ersten Skizze bis zum serienreifen Prototypen südwestlich von Berlin am Seddiner Standort entwickelt und gefertigt werden. In der Fachwelt sind sie anerkannt – sie befinden sich in den Sammlungen von Museen auf der ganzen Welt, sie gewinnen Designpreise und sind Gegenstand verschiedenster Publikationen.

mawa's understanding of design and claim to innovation are reflected in the excellent workmanship of its products, in technical sophistication and in the patents held. All products are originals, which are developed and manufactured at the Seddin site south of Berlin from the first sketch to the production-ready prototype. They are recognized in the professional world — they are in the collections of museums all over the world, they win design awards and are the subject of various publications.

**DESIGN PLUS**  
powered by: **light+building**  
2020



Focus Open 2019  
Special Mention



red dot award 2019  
winner



red dot award 2018  
winner



Auszeichnungen Ständige Sammlung MoMA New York ·  
Museum of Contemporary Art Chicago · Die gute  
Industrieform der Hannover-Messe · Kunstgewerbe-  
museum Hamburg · Haus der Industrieform Essen ·  
Biennale Kortrijk Belgien · design center stuttgart ·  
Museum für Angewandte Kunst Köln · Vitra-Design-  
Sammlung, Weil am Rhein · Sammlung Kunstgewerbe-  
museum Berlin · Designcenter Stuttgart · Sammlung  
Museum für Kunsthandwerk, Frankfurt/Main ·  
Designsammlung Pforzheim · Deutscher Designers'  
Saturday Düsseldorf · Neue Sammlung Nürnberg ·  
Sammlung Grassi Museum Leipzig · Sammlung Stiftung  
Staatliches Museum für Angewandte Kunst, Nürnberg ·  
Form | Messe Frankfurt am Main · Nominierungsliste  
Großer Preis des Mittelstandes · IF Design Award ·  
Sonderausstellung Corbusierhaus Berlin Designcontest  
Osram · Design Plus IF · Nominierung Designpreis der  
Bundesrepublik Deutschland · interior innovation award  
Best of Best · interior innovation award winner ·  
Nominierung German Design Award · German Design  
Award 2017 / 2018 · Designpreis Brandenburg 2017 /  
2021 · Financial Times "FT 1000 Europe's fastest growing  
companies" · Focus Spezial Wachstumschampion ·  
Design Plus Light & Building 2018 / 2020 · GOOD DESIGN  
Award The Chicago Athenaeum 2018 / 2020 / 2021 ·  
Lighting Design Awards 2017 / 2018 · Stylepark Selected ·  
Red Dot Award Product Design Winner 2018 / 2019 ·  
Focus Open Internationaler Designpreis Baden-  
Württemberg 2019 / 2020 / 2021 uvm.



Tisch- und  
Stehleuchten  
*Table and  
floor lamps*







Foto: Leon Kopplow

## Something for everyone

mawa's portfolio in this category is numerous and multifaceted. Small friends like oskar and stuttgart add to young living. Exclusive design classics by Fridtjof Schliephacke and Günter Ssymmank impress experts.

Art lovers can put their treasures in scene even without a suitable wall or ceiling outlet. A nearby socket is sufficient, thanks to the mobile spotlights druff and parkett.

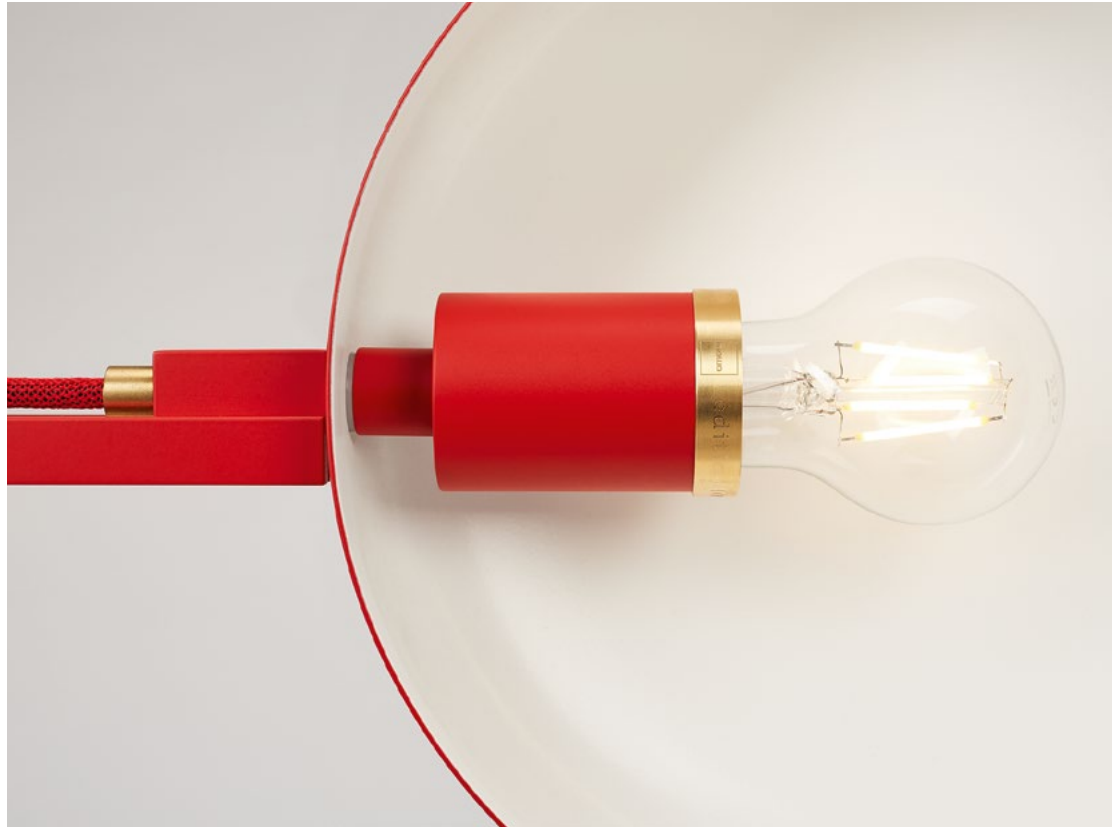
Perfectly processed, in vibrant colors and made of high-quality materials such as glass and porcelain, one or the other model also adorn your domicile.

## Für jeden etwas dabei

mawas Portfolio dieser Kategorie ist vielzählig und facettenreich. Kleine Freunde wie oskar und stuttgart bereichern junges Wohnen. Exklusive Designklassiker von Fridtjof Schliephacke und Günter Ssymmank lassen die Herzen von Kenner:innen höherschlagen.

Kunstliebhaber:innen können ihre Schätze auch ohne passenden Wand- oder Deckenauslass in Szene setzen. Es genügt eine nahegelegene Steckdose, der mobilen Spotlights druff und parkett sei Dank.

Perfekt verarbeitet, in lebendigen Farben und aus hochwertigen Materialien wie Glas und Porzellan bereichert das ein oder andere Modell auch Ihr Domizil.



Foto: Leon Kopplow

# bologna



gangkofner-Edition  
Bodenleuchte mit mundgeblasenem Glaskörper  
Floor lamp with mouth blown glass body

Design: Aloys F. Gangkofner

## gk-bo-bod

Glasvarianten Glass versions



Fassung: E27, max. 60 W, A60  
inklusive Leuchtmittel: E27, A60, 2700 K–2200 K / 806 lm, 9 W  
Kabel: Textilkabel mit Fußdimmer 2,20 m (oder individuell)  
Socket: E27, max. 60 W, A60  
bulb included: E27, A60, 2700 K–2200 K / 806 lm, 9 W  
Cable: textile cable with foot dimmer 2.20 m (or individual)

Fuß Base



Kabel Cable

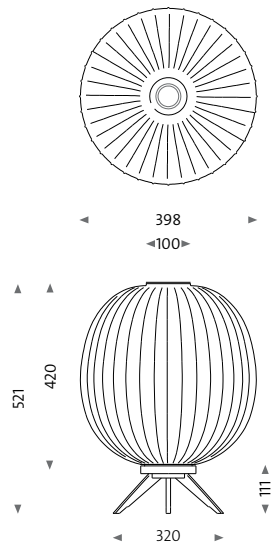

30

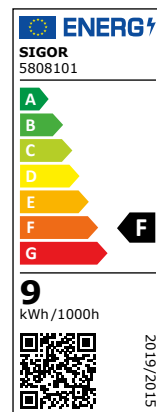

Focus Open 2021  
Special Mention



Foto: Martin Tervoort







# giro / giro-Edition

Design: Serge & Robert Cornelissen

## gi1

Gehäuse giro Housing giro



Gehäuse giro-Edition Housing giro-Edition



LED: 11 W, 2700 K / 1400 lm, Ra > 90

dimmbar über Tastschalter mit Memory-Funktion

Stab: Edelstahl oder Messing

Kabel: schwarzes Flecht kabel 3,47 m

LED: 11 W, 2700 K / 1400 lm, Ra > 90

dimmable via push button with memory function

Rod: stainless steel or brass

Cable: black braided cable 3.47 m

Stab giro Rod giro



Stab giro-Edition Rod giro-Edition

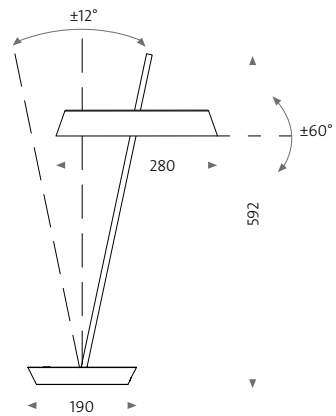

giro



giro-Edition



Foto: ma wa

giro gi1





# heron

Design: Matthias Sauerbruch + Louisa Hutton  
(Sauerbruch Hutton)

## her-sl1

Gehäuse Housing



LED: 12,7W, 2700K/1100lm, 3000K/1200lm,  
4000K/1350lm, Ra >90 (typ. 92)  
dimmbar über Tastschalter mit Memory-Funktion  
Kabel für schwarze und graue Leuchte: schwarzes Textilkabel 3,40 m  
Kabel für blaue Leuchte: dunkelblaues Textilkabel 3,40 m  
LED: 12.7 W, 2700 K/1100 lm, 3000 K/1200 lm,  
4000 K/1350 lm, Ra > 90 (typ. 92)  
dimmable via push button with memory function  
Cable for black and grey light: black textile cable 3.40 m  
Cable for blue light: dark blue textile cable 3.40 m

Kabel Cable

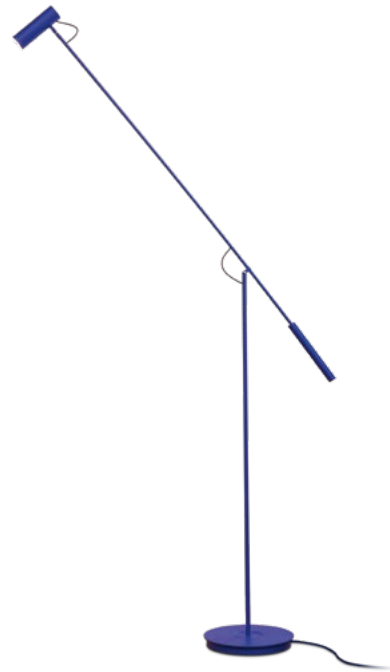
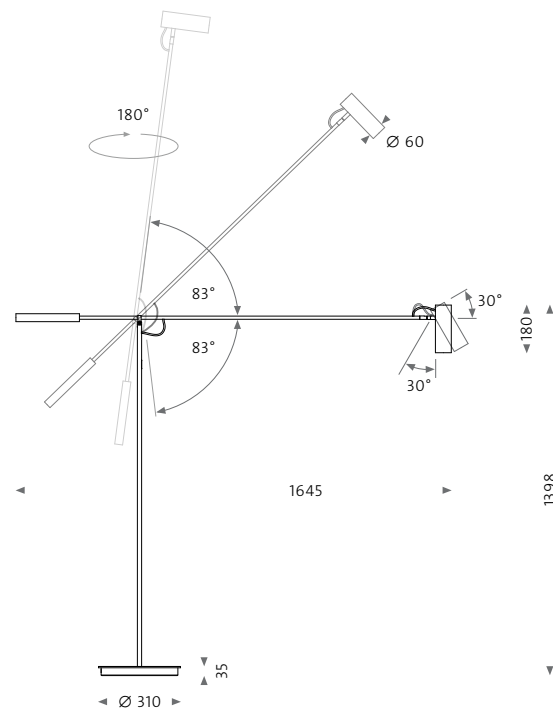

# tadeo 1

Design: Marco Schölzel, Martin Wallroth

ta1

Gehäuse Housing



LED: 19W, 2700K/2100lm, Ra > 90  
dimmbar über Tastschalter mit Memory-Funktion  
Kabel: schwarzes Flechtkabel 3,47 m  
LED: 19W, 2700K/2100lm, Ra > 90  
dimmbare via push button with memory function  
Cable: black braided cable 3.47 m

Taster Button



Foto: Martin Teuvoort





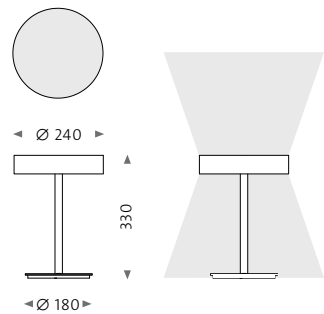

# tadeo 2

Design: Marco Schölzel, Martin Wallroth

## ta2

Gehäuse Housing



LED: 27,5W, 2700K/2400lm, Ra > 90  
dimmbar über Tastschalter mit Memory-Funktion  
Kabel: schwarzes Flecht-kabel 3,47 m  
LED: 27.5 W, 2700 K / 2400 lm, Ra > 90  
dimmable via push button with memory function  
Cable: black braided cable 3.47 m

Taster Button



Foto: Martin Tervoort





Foto: mawa

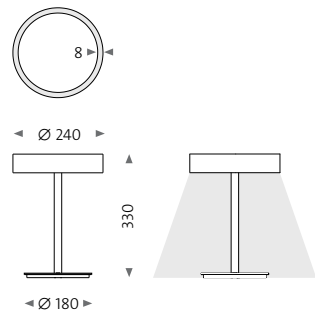

Foto: Martin Tervoort

# polly

Design: Martin Wallroth

## pl1

Gehäuse Housing



Fassung: E27, max. 60 W, exklusive Leuchtmittel  
 dimmbar über Tastschalter mit Memory-Funktion  
 Kabel: graues Textilkabel 2,40 m

Socket: E27, max. 60 W, bulb not included  
 dimmable via push button with memory function  
 Cable: grey textile cable 2.40 m

Taster Button

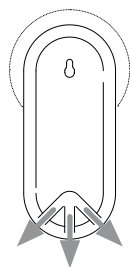
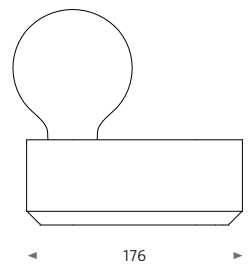

Kabelausslass links,  
 rechts oder mittig  
 Cable outlet left,  
 right or center

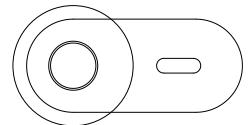

polly Tischleuchte



polly Wandleuchte







# stuttgart 2

Design: Michele Rami

sg2

Gehäuse Housing



Fassung: E27, max. 40 W, exklusive Leuchtmittel  
 dimmbar über Tastschalter mit Memory-Funktion  
 Kabel mit Dimmschalter: graues Textilkabel 1,80 m  
 Socket: E27, max. 40 W, bulb not included  
 dimmable via push button with memory function  
 Cable with dimmer switch: grey textile cable 1.80 m



Beispielhafte Darstellung mit Leuchtmittel  
 Exemplary illustration with illuminant

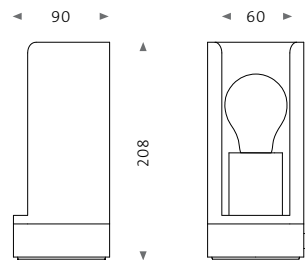

frei drehbar in beide Richtungen  
 freely rotatable in both directions

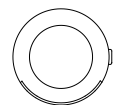



# fbl-sl

fbl Serie

Design: Jan Blieske, Jan Dinnebier, mawa

## fbl-sl

Gehäuse Housing



LED: 15 W, 2700 K/1200 lm, 3000 K/1270 lm, 4000 K/1400 lm

Ra > 95 (typ. 97)

dimmbar über Tastschalter mit Memory-Funktion

Kabel: schwarzes Flechtkabel 2,00 m

LED: 15 W, 2700 K/1200 lm, 3000 K/1270 lm, 4000 K/1400 lm

Ra > 95 (typ. 97)

dimmable via push button with memory function

Cable: black braided cable 2.00 m

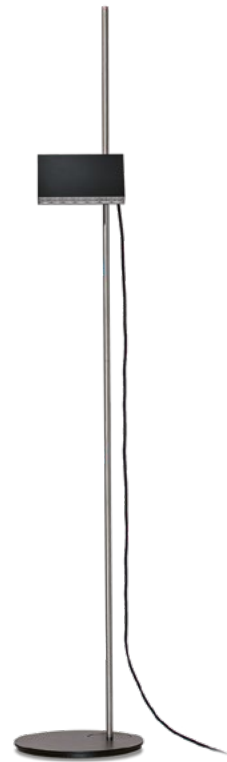
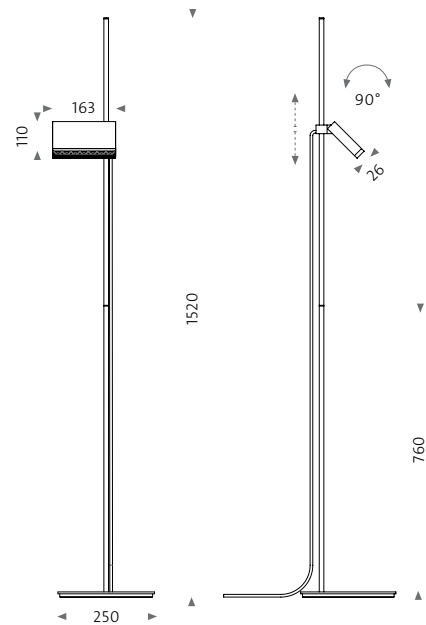





# oskar / oskar dim

Design: Marco Schölzel, Martin Wallroth



os 1  
os 1-dim

Gehäuse os 1 Housing os 1



Gehäuse os 1-dim Housing os 1-dim



Fassung: E27, max. 60 W, exklusive Leuchtmittel

os 1: schaltbar

Kabel mit Schnurschalter: Textilkabel 2,40 m

os 1-dim: dimmbar

Kabel mit Dimmschalter: Textilkabel 1,80 m

Socket: E27, max. 60 W, bulb not included

os 1: switchable

Cable with key switch: textile cable 2.40 m

os 1-dim: dimmable

Cable with dimmer switch: textile cable 1.80 m

Kabel Cable

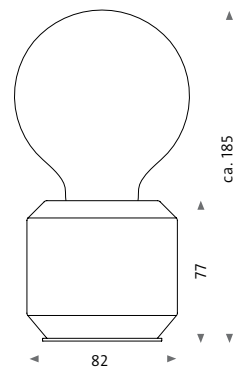

beispielhafte Darstellung  
mit Leuchtmittel Ø 95 mm  
exemplary illustration  
with illuminant Ø 95 mm

os 1



os 1-dim



Foto: Leon Kopplow



Fotos: Leon Kopplow



# schliephacke – berliner bratpfanne®

Design: Fridtjof Schliephacke, 1959

Sammlung Kunstgewerbemuseum Berlin  
Collection Kunstgewerbemuseum Berlin

sch1

Gehäuse Housing



Fassung: E27, max. 100 W, exklusive Leuchtmittel

Kabel: schwarzes Textilkabel 2,10 m

Socket: E27, max. 100 W, bulb not included

Cable: black textile cable 2.10 m

Fuß Base



Foto: Werner Huthmacher

schliephacke sch1; Trauerhalle Baumschulenweg, Berlin  
schliephacke sch1; mourning hall Baumschulenweg, Berlin

# schliephacke-Edition – berliner bratpfanne®

schliephacke-Edition

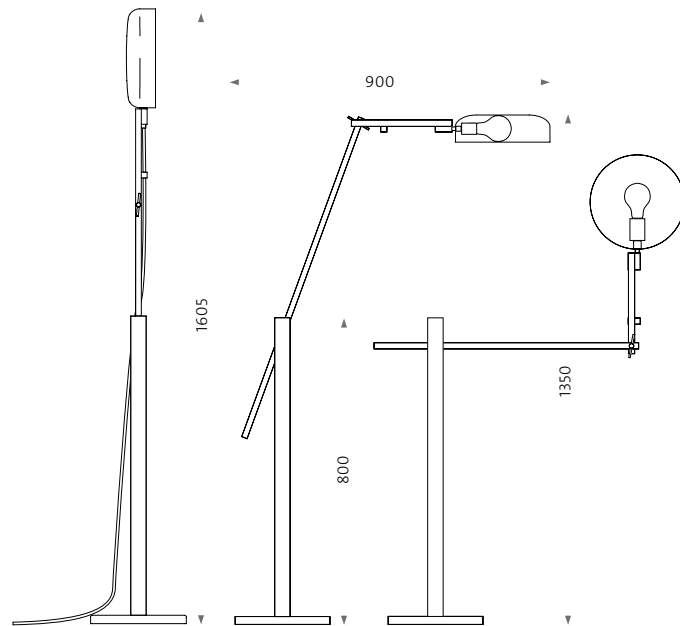
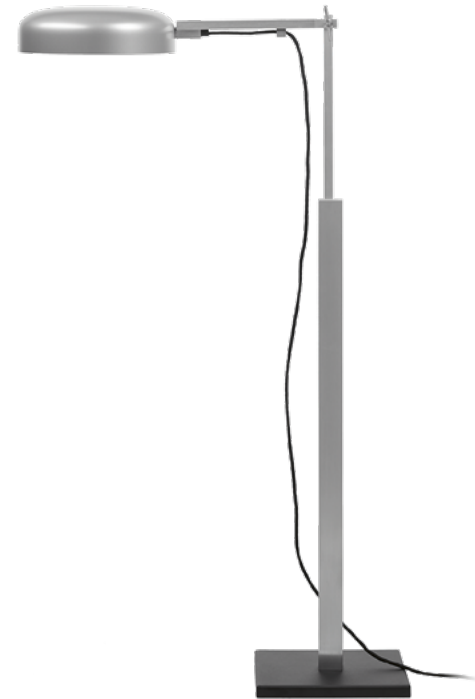
Design: Prof. Fridtjof Schliephacke  
Editions-Farbauswahl: Martin Wallroth

sch1

Gehäuse Housing



Fassung: E27, max. 100 W, exklusive Leuchtmittel

Kabel: Textilkabel 2,10 m

Socket: E27, max. 100 W, bulb not included

Cable: textile cable 2.10 m

Fuß Base



Kabel Cable



Foto: Leon Kopplow

schliephacke-Edition sch1

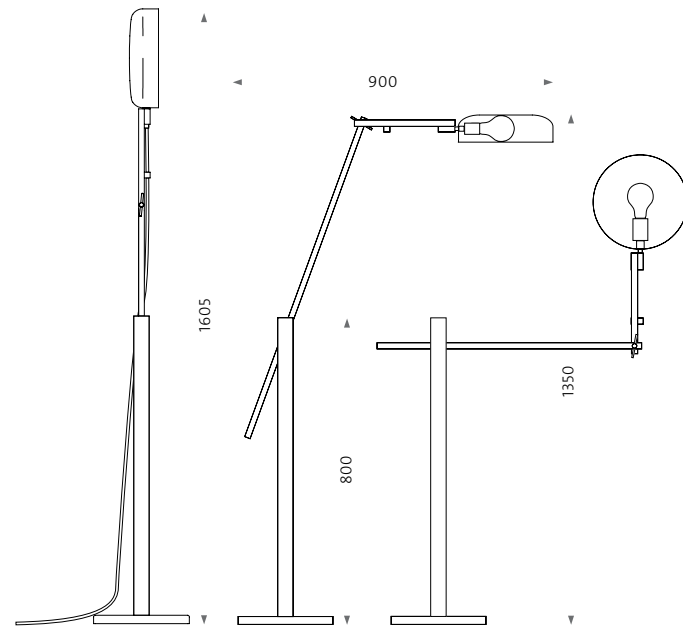

# ssymmank

Design: Prof. Günter Ssymmank, 1959

Museum of Modern Art, New York; Sammlung Kunstgewerbemuseum Berlin  
Museum of Modern Art, New York; Collection Kunstgewerbemuseum Berlin

## sy1

Gehäuse Housing



Fassung: E14, max. 40 W, exklusive Leuchtmittel  
Kabel: weiß, 2,80 m  
Socket: E14, max. 40 W, bulb not included  
Cable: white, 2.80 m

Blattelement Leaf element

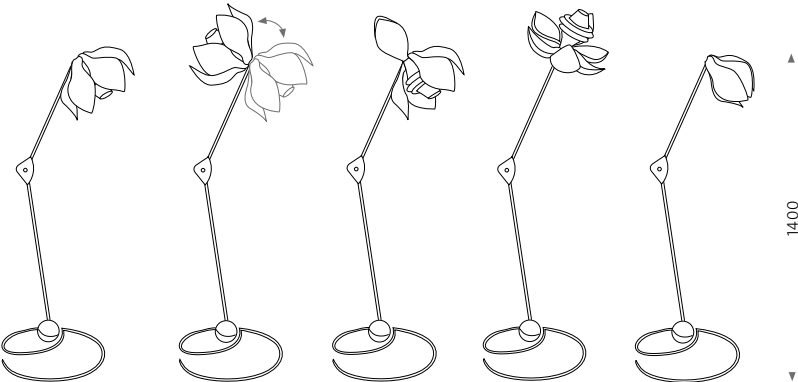

ssymmank-Pendelleuchten  
ab Seite 142  
ssymmank pendant lights  
from page 142



Foto: ma wa





# pure mini

pure Serie

Design: Marco Schölzel, Martin Wallroth

## pu-mi-LED-G2

Gehäuse Housing



LED: 11 W, 2700 K / 800 lm, Ra > 90 (typ. 92)  
dimmbar über Tastschalter mit Memory-Funktion  
Kabel: schwarzes Flechtkabel 3,52 m  
LED: 11 W, 2700 K / 800 lm, Ra > 90 (typ. 92)  
dimmable via push button with memory function  
Cable: black braided cable 3.52 m

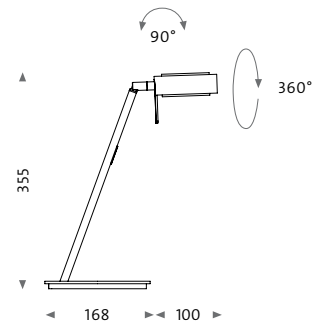

# pure 1

pure Serie

Design: Marco Schölzel, Martin Wallroth

## pu-1-LED-G2

Gehäuse Housing



LED: 11 W, 2700 K / 800 lm, Ra > 90 (typ. 92)  
dimmbar über Tastschalter mit Memory-Funktion  
Kabel: schwarzes Flecht-kabel 3,52 m  
LED: 11 W, 2700 K / 800 lm, Ra > 90 (typ. 92)  
dimmable via push button with memory function  
Cable: black braided cable 3.52 m



Foto: Werner Hühnmacher

pure 1 pu-1-LED-G2



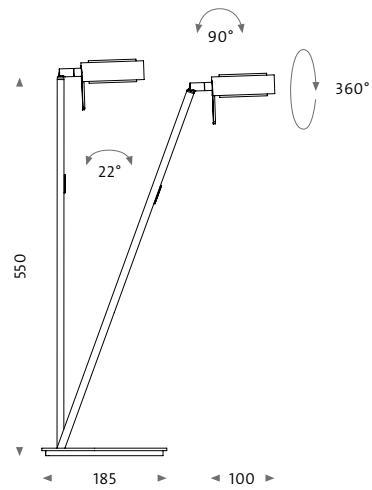

# pure 2

pure Serie

Design: Marco Schölzel, Martin Wallroth

## pu-2-LED-G2

Gehäuse Housing



LED: 11 W, 2700 K / 800 lm, Ra > 90 (typ. 92)  
dimmbar über Tastschalter mit Memory-Funktion  
Kabel: schwarzes Flechtkabel 2,37 m  
LED: 11 W, 2700 K / 800 lm, Ra > 90 (typ. 92)  
dimmbare via push button with memory function  
Cable: black braided cable 2.37 m



Foto: Werner Huthmacher

pure 2 pu-2-LED-G2





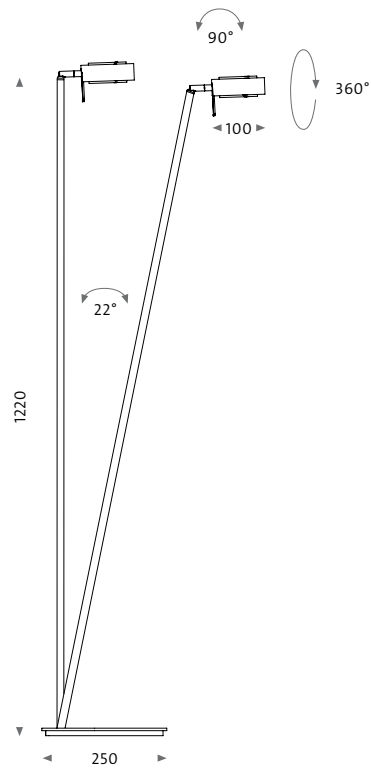

# parkett

wittenberg 4.0 Serie

Design: Jan Dinnebier, Martin Wallroth

wi4-bod-2e-hb

Gehäuse Housing



LED: 2 x 12,7 W, 2700 K / 1100 lm, Ra > 90 (typ. 92)

dimmbar über Tastschalter mit Memory-Funktion

Kabel: schwarzes Textilkabel 2,20 m

LED: 2 x 12.7 W, 2700 K / 1100 lm, Ra > 90 (typ. 92)

dimmbare via push button with memory function

Cable: black textile cable 2.20 m



beidseitiger Dimmtaster mit  
Memory-Funktion zur getrennten  
Ansteuerung beider Lichtköpfe  
dimmer switch on both sides  
with memory function for separate  
control of both light heads

Kabelausschlass an langer und  
kurzer Gehäusesseite  
cable outlet on long and  
short side of housing

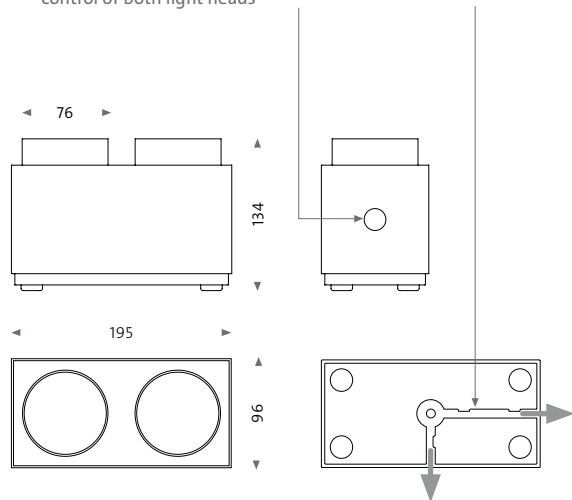



# druff

wittenberg 4.0 Serie

Design: Jan Dinnebier, Martin Wallroth

wi4-reg-2e-hb

Gehäuse Housing



LED: 2 × 12,7 W, 2700 K / 1100 lm,  
3000 K / 1200 lm, 4000 K / 1350 lm  
Ra > 90 (typ. 92)

dimmbar über Tastschalter mit Memory-Funktion

Kabel: graues Textilkabel 2,30 m

LED: 2 × 12.7 W, 2700 K / 1100 lm,  
3000 K / 1200 lm, 4000 K / 1350 lm  
Ra > 90 (typ. 92)

dimmable via push button with memory function

Cable: grey textile cable 2.30 m



Taster mit Memory-Funktion  
dimmer switch with memory  
function



Foto: ma wa

wittenberg 4.0 druff wi4-reg-2e-hb

Pendelleuchten  
*Pendant lights*



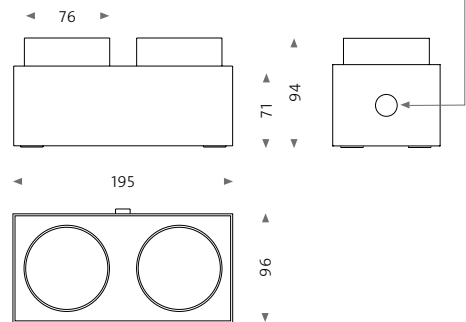

# Zwischen Tradition und Moderne

mawa denkt in die Zukunft, weiß Vergangenes zu schätzen und bewegt sich souverän zwischen den Zeiten. Ausgewählte Arbeiten des Glasgestalters Aloys F. Gangkofner wurden neu aufgelegt und erwecken Glaskunst aus den 50er-Jahren zu neuem Leben. In Verbindung mit selbst entwickelten, gebrauchsfreundlichen Pendelmechanismen ist diese Reedition eine Ode an traditionelles Handwerk.

Moderne CNC-Fertigung spiegelt sich im Leuchtenmodell porto wider. Die Außenhaut dieser industriell anmutenden Form wird aus einem Stück Aluminium gefaltet und lässt sich mittels beidseitiger Pendelscharniere nach Belieben verlängern. Ob als Einzelsegment oder in Gruppe – diese Entwicklung behauptet sich souverän in Wohn- und Arbeitswelt.



Foto: Leon Kopplow



Foto: mawa

## Between tradition and modernity

mawa considers the future, appreciates the past and moves confidently between times. Selected works by the glass designer Aloys F. Gangkofner have been reissued and bring glass art from the 1950s to new life. Together with self-developed, user-friendly pendant mechanisms, this re-edition is an ode to traditional crafts.

Modern CNC production is reflected in the luminaire model porto. The outer skin of this industrial-looking shape is folded from a single piece of aluminum and can be extended as desired using the pendant hinges on both sides. Whether as a single segment or in a group, this luminaire stands its ground confidently in living and working environments.

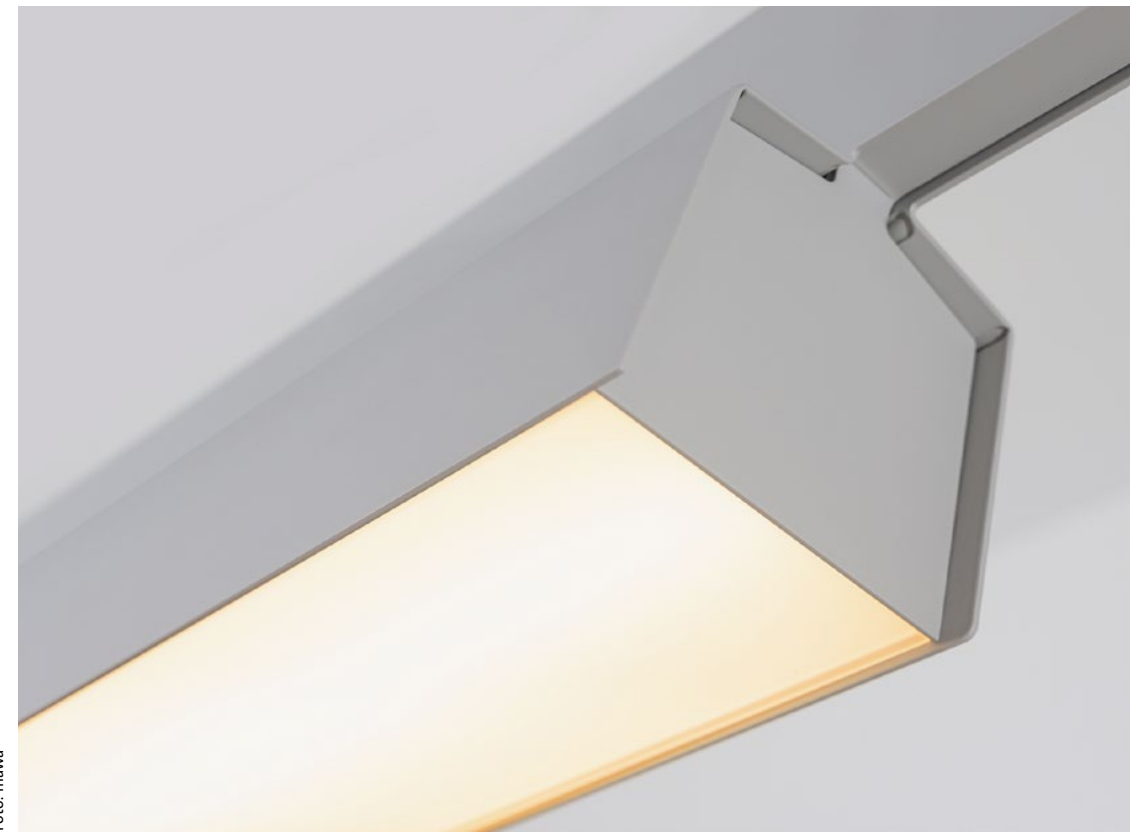



# porto

Design: Prof. Hermann August Weizenegger  
Engineering: mawa

## pt1

Gehäuse Housing



LED: 36 W, 2700 K / 4233 lm, 3000 K / 4443 lm,  
4000 K / 4584 lm, Ra 90

Gesamtpendellänge inklusive Leuchte: 3,40 m  
dimmbar

LED: 36 W, 2700 K / 4233 lm, 3000 K / 4443 lm,  
4000 K / 4584 lm, Ra 90

Pendant length including light: 3.40 m  
dimmmable

Highlights Highlights

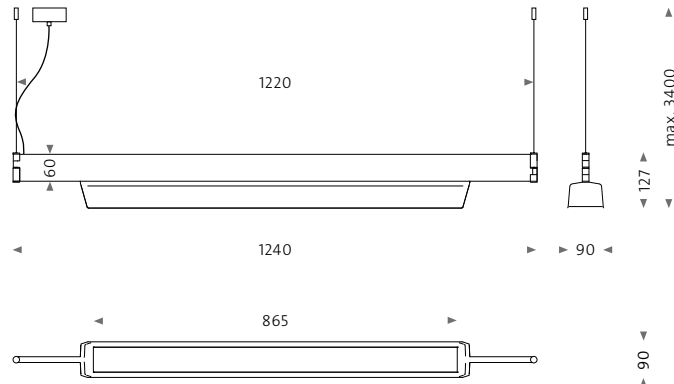

mehr Informationen zum  
Erweiterungsmodul online  
more information about the  
extension module online

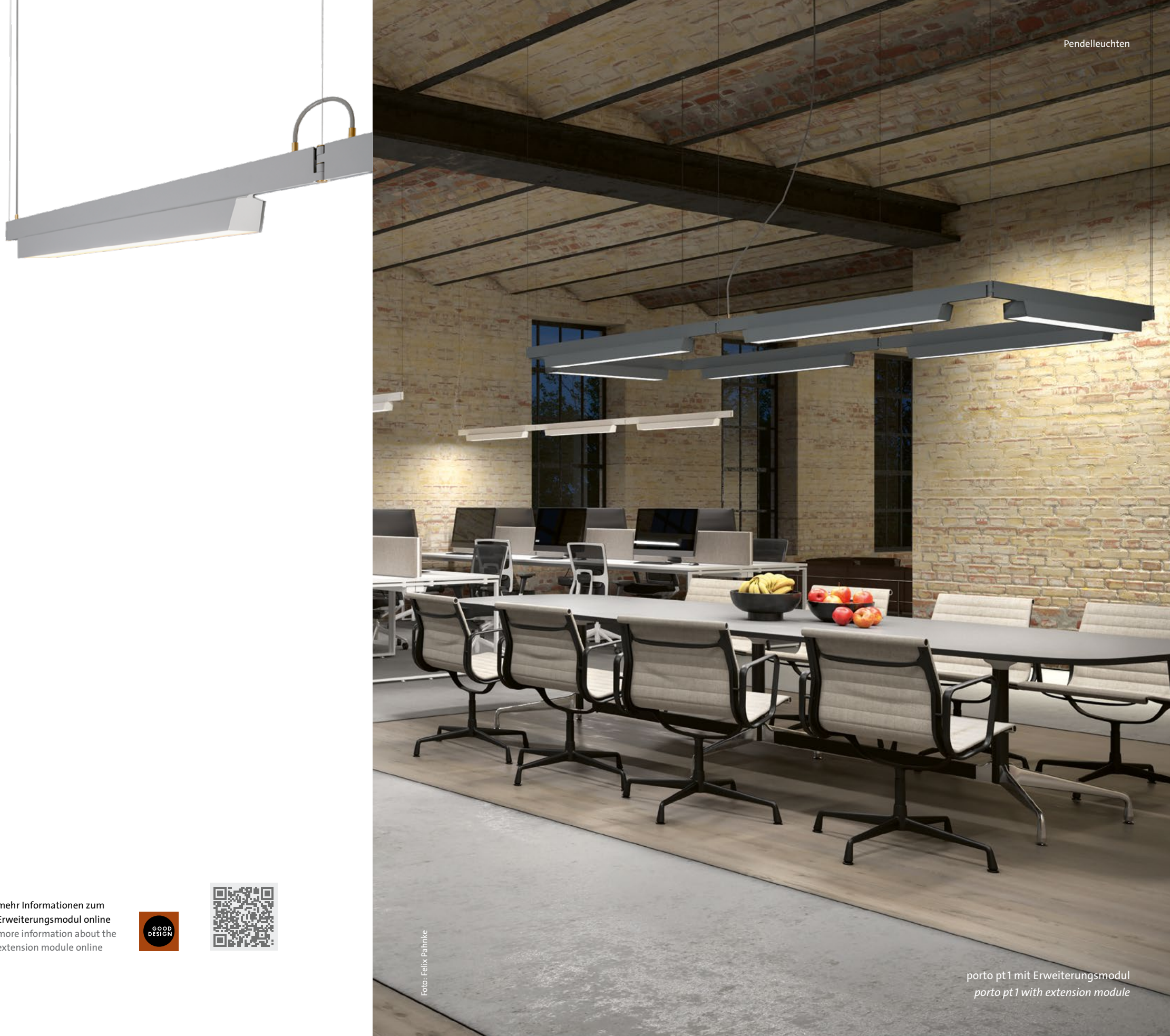











# bergamo

gangkofner-Edition  
Pendelleuchte mit mundgeblasenem Glaskörper  
Pendant light with mouth blown glass body

Design: Aloys F. Gangkofner

gk-be

Glasvarianten Glass versions



Fassung: E27, max. 60 W, exklusive Leuchtmittel  
optional Bluetooth dimmbar  
Gesamtpendellänge inklusive Leuchte (Standard): 2,70 m  
Socket: E27, max. 60 W, bulb not included  
optionally bluetooth dimmable  
Pendant length including light (standard): 2.70 m

Pendel / Pendel-Highlights  
Pendant / Pendant highlights



Textilkabel Textile cable

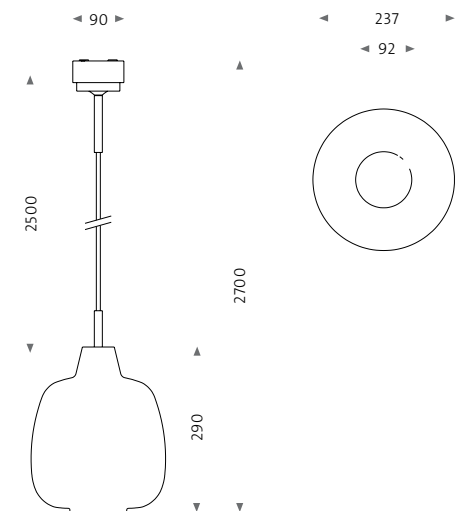



gangkofner-Edition granada gk-gr

Foto: Leon Kopplow



Foto: Zoëy Braun

gangkofner-Edition granada gk-gr, wittenberg 4.0 wi4-ab-1r; Haus F22, Gerlingen



# granada

gangkofner-Edition  
Pendelleuchte mit mundgeblasenem Glaskörper  
Pendant light with mouth blown glass body

Design: Aloys F. Gangkofner

gk-gr

Glasvarianten Glass versions



Fassung: E27, max. 60 W, exklusive Leuchtmittel  
optional Bluetooth dimmbar  
Gesamtpendellänge inklusive Leuchte (Standard): 2,87 m  
Socket: E27, max. 60 W, bulb not included  
optionally bluetooth dimmable  
Pendant length including light (standard): 2.87 m

Pendel / Pendel-Highlights  
Pendant / Pendant highlights



Textilkabel Textile cable

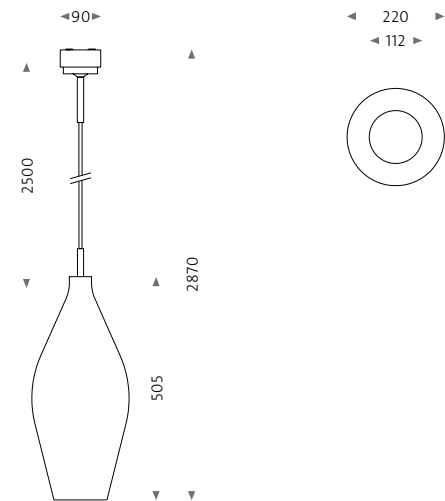

# bologna

gangkofner-Edition  
Pendelleuchte mit mundgeblasenem Glaskörper  
Pendant light with mouth blown glass body

Design: Aloys F. Gangkofner

gk-bo  
gk-bo2

Glasvarianten Glass versions



Fassung: E27, max. 60 W, exklusive Leuchtmittel  
optional Bluetooth dimmbar  
Gesamtpendellänge inklusive Leuchte (Standard): gk-bo 2,80 m, gk-bo2 2,83 m  
Socket: E27, max. 60 W, bulb not included  
optionally bluetooth dimmable  
Pendant length including light (standard): gk-bo 2.80 m, gk-bo2 2.83 m

Pendel / Pendel-Highlights  
Pendant / Pendant highlights



Textilkabel Textile cable



Foto: Leon Koppilow



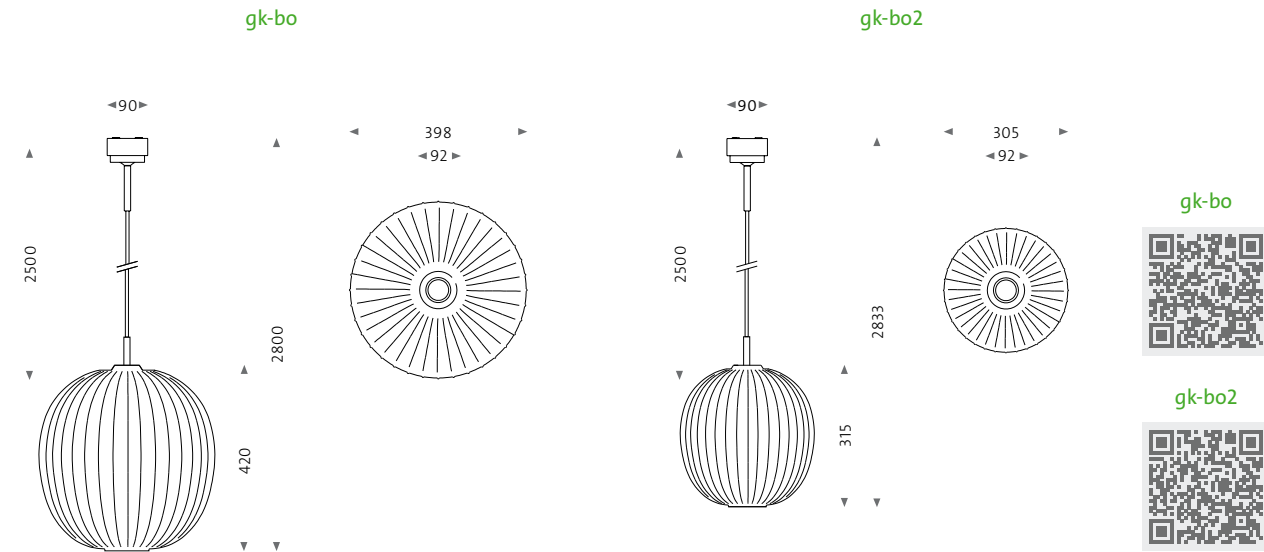

# pisa

gangkofner-Edition  
Pendelleuchte mit mundgeblasenem Glaskörper  
Pendant light with mouth blown glass body

Design: Aloys F. Gangkofner

## gk-pi

Glasvarianten Glass versions



Fassung: E27, max. 60 W, exklusive Leuchtmittel  
optional Bluetooth dimmbar  
Gesamtpendellänge inklusive Leuchte (Standard): 2,90 m  
Socket: E27, max. 60 W, bulb not included  
optionally bluetooth dimmable  
Pendant length including light (standard): 2.90 m

Pendel / Pendel-Highlights  
Pendant / Pendant highlights



Textilkabel Textile cable

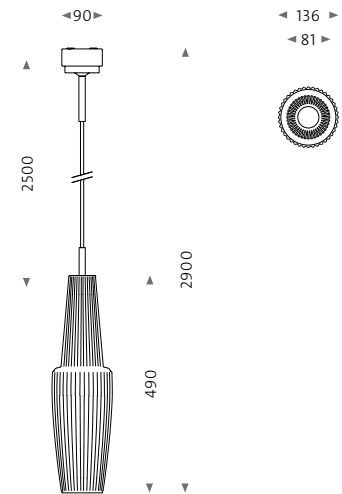



# venezia

gangkofner-Edition  
Pendelleuchte mit mundgeblasenem Glaskörper  
Pendant light with mouth blown glass body

Design: Aloys F. Gangkofner

## gk-ven

Glasvarianten Glass versions



Fassung: E27, max. 60 W, exklusive Leuchtmittel  
optional Bluetooth dimmbar  
Gesamtpendellänge inklusive Leuchte (Standard): 2,90 m  
Socket: E27, max. 60 W, bulb not included  
optionally bluetooth dimmable  
Pendant length including light (standard): 2.90 m

Pendel / Pendel-Highlights  
Pendant / Pendant highlights



Textilkabel Textile cable



Foto: Martin Tervoort

# vesuvio

gangkofner-Edition  
Pendelleuchte mit mundgeblasenem Glaskörper  
Pendant light with mouth blown glass body

Design: Aloys F. Gangkofner

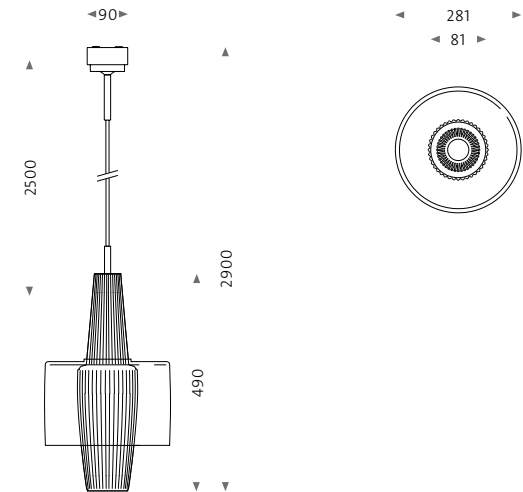
## gk-ves

Glasvarianten Glass versions



Fassung: E27, max. 60 W, exklusive Leuchtmittel  
optional Bluetooth dimmbar  
Gesamtpendellänge inklusive Leuchte (Standard): 2,66 m  
Socket: E27, max. 60 W, bulb not included  
optionally bluetooth dimmable  
Pendant length including light (standard): 2.66 m

Pendel / Pendel-Highlights  
Pendant / Pendant highlights



Textilkabel Textile cable

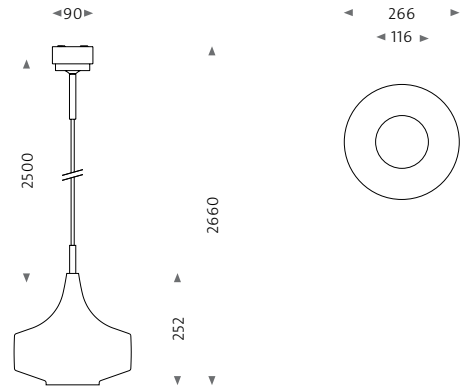



# Details der gangkofner-Edition

## Details of the gangkofner-Edition

### Baldachin und Pendel mit optionalen Highlights in messing gebürstet oder roségold glänzend

#### Canopy and suspension with optional highlights in brass brushed or rosegold shiny







-  messing gebürstet 2  
brass brushed 2  
(-me2)
-  messing gebürstet 1  
brass brushed 1  
(-me1)
-  weiß matt (9016)  
schwarz matt (9005)  
white matt (9016)  
black matt (9005)  
(-9016 / -9005)
-  roségold glänzend 1  
rosegold shiny 1  
(-rg 1)
-  roségold glänzend 2  
rosegold shiny 2  
(-rg 2)

### Farbige Textilkabel und maßgeschneiderte Pendellängen

#### Colored textile cable and custom suspension lengths



-  weiß  
white  
(-wh)
-  schwarz  
black  
(-bk)
-  grau  
grey  
(-gy)
-  blau  
blue  
(-bu)

Die Kabel der gangkofner-Edition sind serienmäßig mit Stahlseil verstärkt und mit feinen Thin-Weave-Textilien aus gewebtem Polyester in vier Farben umklöppelt.

**WICHTIG:** Kabel der gangkofner-Edition haben eine Standardkabellänge von 2,50 Metern ohne Glas. Bei Bedarf kürzen wir für Sie das Kabel auf die gewünschte Länge. Bitte geben Sie bei jeder Bestellung Ihre gesamte Wunschlänge an: Maß ab Deckenunterkante bis Unterkante Leuchtenglas.

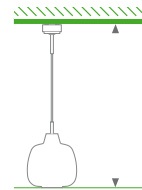

Bitte immer Wunschlänge angeben!  
Please always define your optional length!

Zuschnitt (< 2500 mm) pre-cut (gk-cbl-zs)  
Sonderlänge (> 2500 mm) special length (gk-cbl-sl)

Including a steel core for additional length stability, the cables for gangkofner-Edition are covered with braided, thin-weave textiles made of fine woven polyester in four colors.

**Important:** Cables for gangkofner-Edition have a standard length of 2.50 meters without glass. On request, we trim the cable to the desired length. Please always add the required length of the whole lamp to your order: distance between the ceiling bottom and the bottom of the pendant glass.

### Baldachin mit Köpfchen

#### Savvy canopy

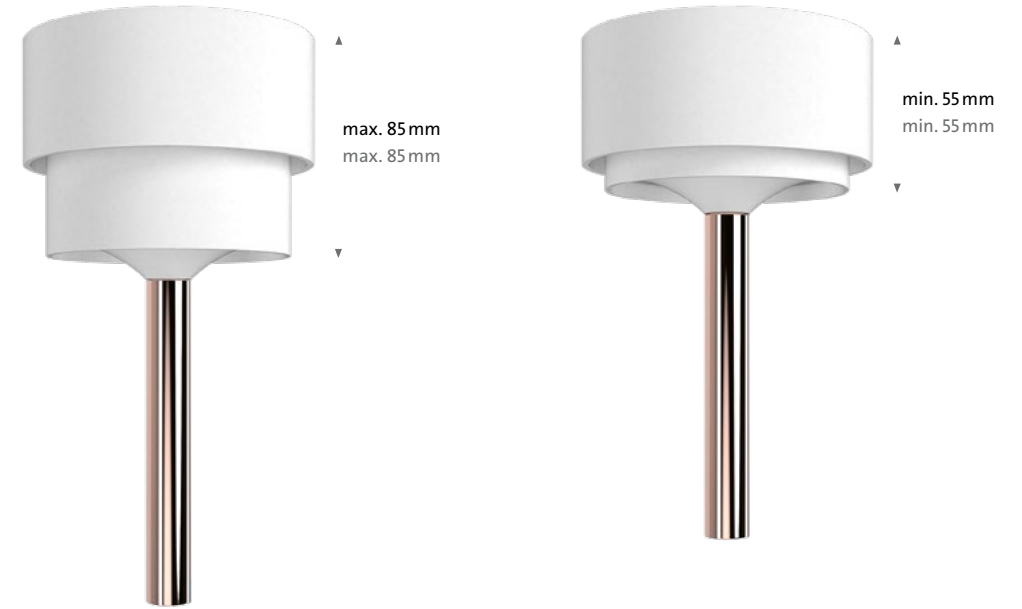

Dieser Baldachin (Ø 90 mm) sitzt. Und alles, was aus der Decke kommt, sitzt sauber darunter. Dank variabler Höhen werden Kabel, Steuerelemente und kleinere Gashaken elegant kaschiert.

This canopy (Ø 90 mm) is well-designed; everything coming out of the ceiling is cleverly hidden away. Thanks to variable heights, electrical cables, controllers, and smaller hooks are elegantly concealed.

### Fast wie unsichtbar

#### Almost invisible



mawas transparente, bruchssichere Makrolon®-Mechanik hält den Glaskörper sicher am Pendel und lässt ihn elegant schweben.

mawa's transparent, shatterproof Makrolon®-mechanism secures the glass body to the pendant, letting it nearly appear to float.

# gangkofner-Edition und lineare Mehrfachbaldachine

## gangkofner-Edition and linear multiple canopies

### Standard Standard

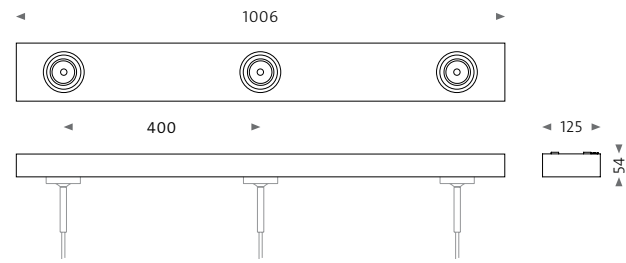

### Individuelle Längen < 1 m oder > 1 m Individual lengths < 1 m or > 1 m

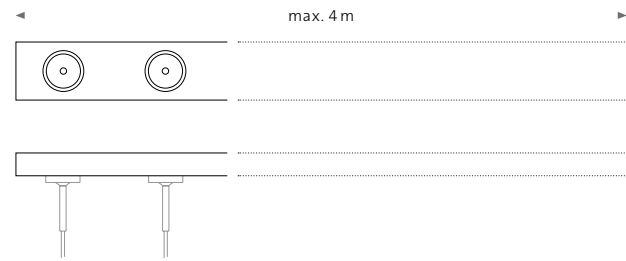

**Wichtig:** Mindestabstand zwischen Leuchten ist abhängig von Leuchtenform und gewünschter Abpendelungshöhe der Gläser zueinander.  
**Important:** Minimum distance between canopies depends on the shape of the luminaire and the desired suspension height of the glasses in relation to each other.

### Sonderform auf Anfrage Special shape on request

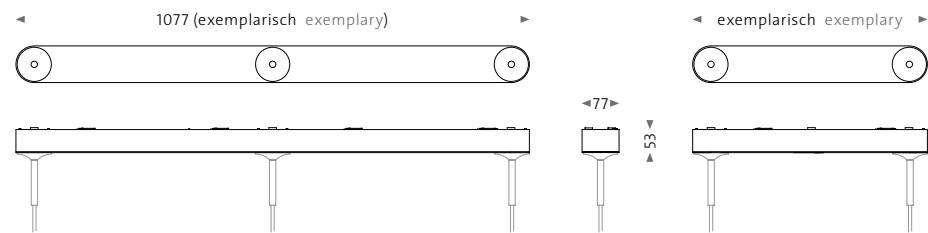

gangkofner-Edition bergamo gk-be mit linearen 3er Mehrfachbaldachin gk-ba-3l  
gangkofner-Edition bergamo gk-be with linear 3-panel multiple canopy gk-ba-3l

Foto: Felix Palmke



# gangkofner-Edition und runde Mehrfachbaldachine gangkofner-Edition and round multiple canopies

## Varianten des Mehrfachbaldachins rund Variants of multiple canopy round

Standardausführungen für 3–7 Leuchten  
Standard versions for 3–7 luminaires

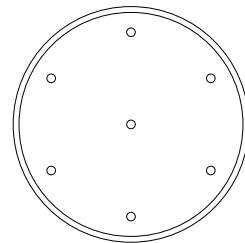

gk-ba-7r

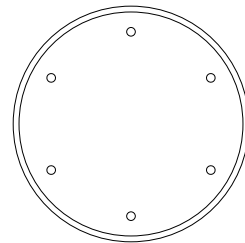

gk-ba-6r

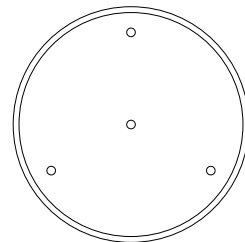

gk-ba-4r

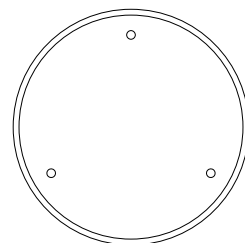

gk-ba-3r

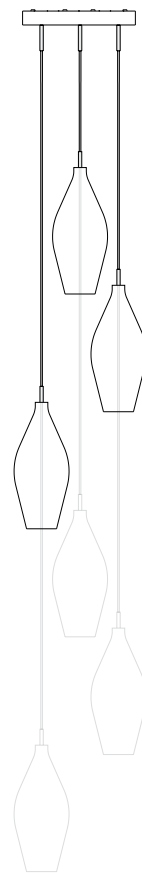

-  bergamo  
gk-be
-  bologna  
gk-bo
-  bologna  
gk-bo2
-  granada  
gk-gr
-  venezia  
gk-ven
-  pisa  
gk-pi
-  vesuvio  
gk-ves









# d28

Design: Lars Dinter

d28-ab  
d28-eb

Gehäuse Housing



LED: 5 W, 2700 K / 400 lm, Ra > 80, inklusive Betriebsgerät dimmbar

Gesamtpendellänge inklusive Leuchte: 2,60 m

LED: 5 W, 2700 K / 400 lm, Ra > 80, control gear included dimmable

Pendant length including light: 2.60 m

Kabel Cable



d28-ab

▶ 50 ◀

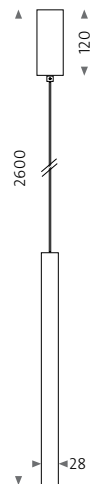

d28-eb

◀ 76 ▶

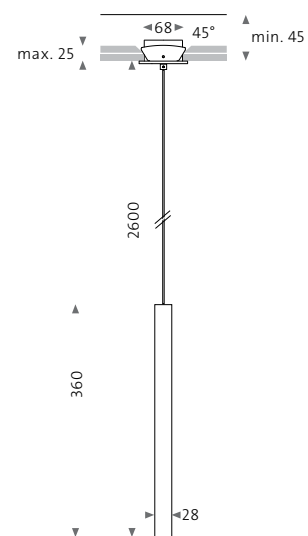

Deckenausschnitt:  
Ceiling cut-out:  
Ø 68 mm

d28-ab



d28-eb



Pendelleuchten



Architektur: Ritter Lockisch Architekten; Kunstwerk: Courtesy Sammlung Coetz, München; Foto: Brígida González

d28 d28-eb; goetzpartners, München

# glaskugelleuchte

Pendelleuchte mit mundgeblasenem Glaskörper  
Pendant light with mouth blown glass body

Design: Martin Wallroth

ku2 s / p  
ku3 s / p  
ku4 s / p

Glasvarianten Glass versions



Fassung: E27, max. 60 W, exklusive Leuchtmittel

Gesamtpendellänge inklusive Leuchte (Standard): ku2 s 2,50 m, ku3 s 2,60 m, ku4 s 2,70 m

Abpendelung: transparentes Kabel mit Fangseil (s) oder Pendelstange (p) (optionale Pendelstangenverlängerung)

Socket: E27, max. 60 W, bulb not included

Pendant length including light (standard): ku2 s 2.50 m, ku3 s 2.60 m, ku4 s 2.70 m

Pendant versions: transparent cable with safety rope (s) or pendulum rod (p) (pendulum rod extension available)

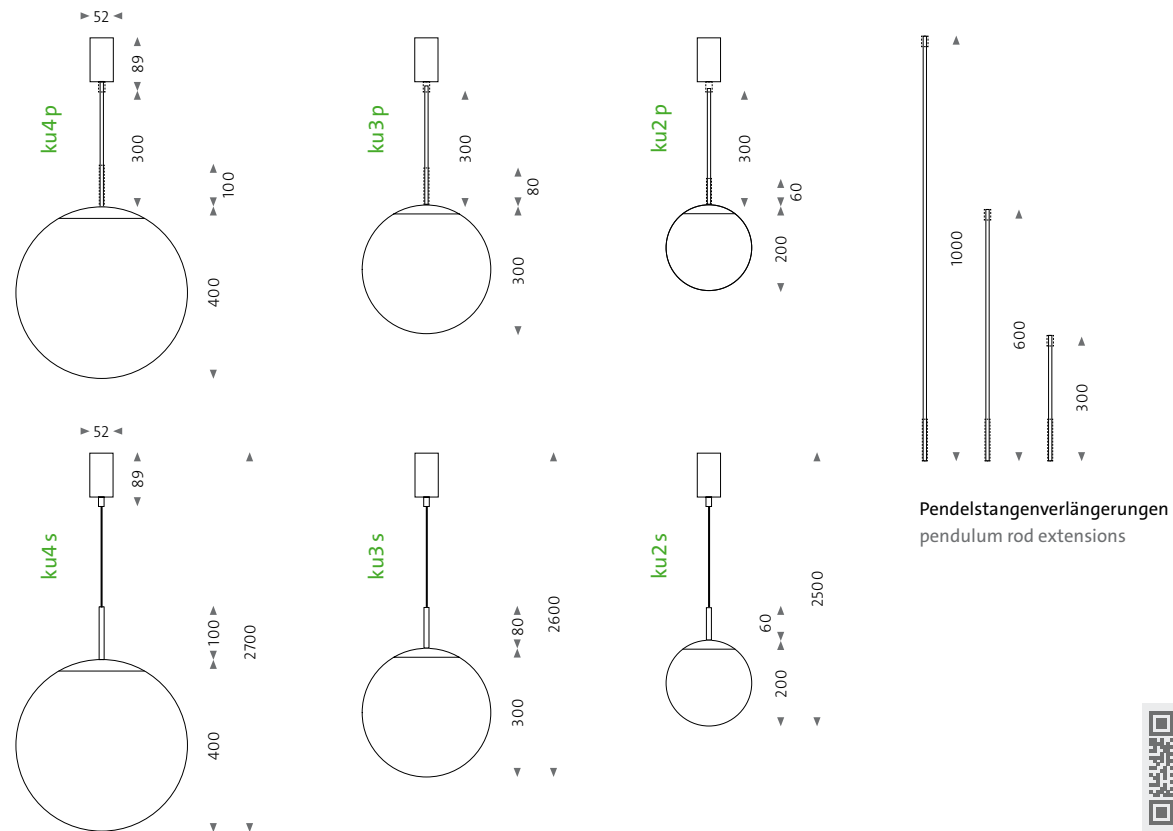





Pendelleuchten

Fotos: Stefan Wolf Lucks

glaskugelleuchte led ku3-led, Waldkliniken Eisenberg



# glaskugelleuchte LED

Pendelleuchte mit mundgeblasenem Glaskörper  
 Pendant light with mouth blown glass body

Design: Daniel Frey, Martin Wallroth

ku2-LED  
 ku3-LED  
 ku4-LED

Glasvarianten Glass versions



LED: 12,7 W, 2700 K/1100 lm, 3000 K/1200 lm, 4000 K/1350 lm

Ra > 90 (typ. 92), dimmbar

Gesamtpendellänge inklusive Leuchte (Standard): ku2-LED 2,50 m, ku3-LED 2,60 m, ku4-LED 2,70 m

LED: 12.7 W, 2700 K/1100 lm, 3000 K/1200 lm, 4000 K/1350 lm

Ra > 90 (typ. 92), dimmable

Pendant length including light (standard): ku2-LED 2.50 m, ku3-LED 2.60 m, ku4-LED 2.70 m

Mönchskappe und Baldachin

Monk's cap and canopy



ku2-LED

ku3-LED

ku4-LED

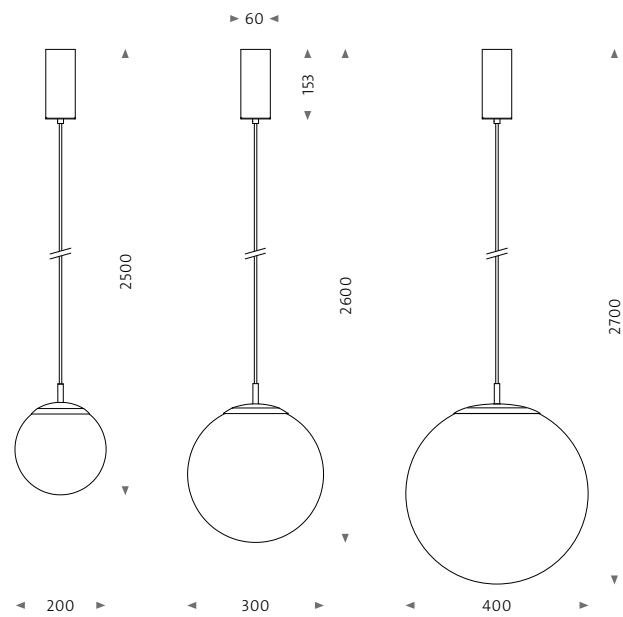

ku2-LED



ku3-LED



ku4-LED



Foto: Stefan Wolf Lucks





Pendelleuchten

Café Zickzack

Café Zickzack

Foto: Andreas Horisky

goldener schnitt gs1; Café Zickzack Messe Frankfurt, Frankfurt am Main



# goldener schnitt 1

Design: Lutz Köbele-Lipp

gs1

Gehäuse Housing



LED: 135 W, 3000 K / 11520 lm, Ra > 90 (typ. 92)  
dimmbar  
Gesamtpendellänge inklusive Leuchte: transparentes Kabel 2,75 m  
LED: 135 W, 3000 K / 11520 lm, Ra > 90 (typ. 92)  
dimmbare  
Pendant length including light: transparent cable 2.75 m



Foto: ma/wa



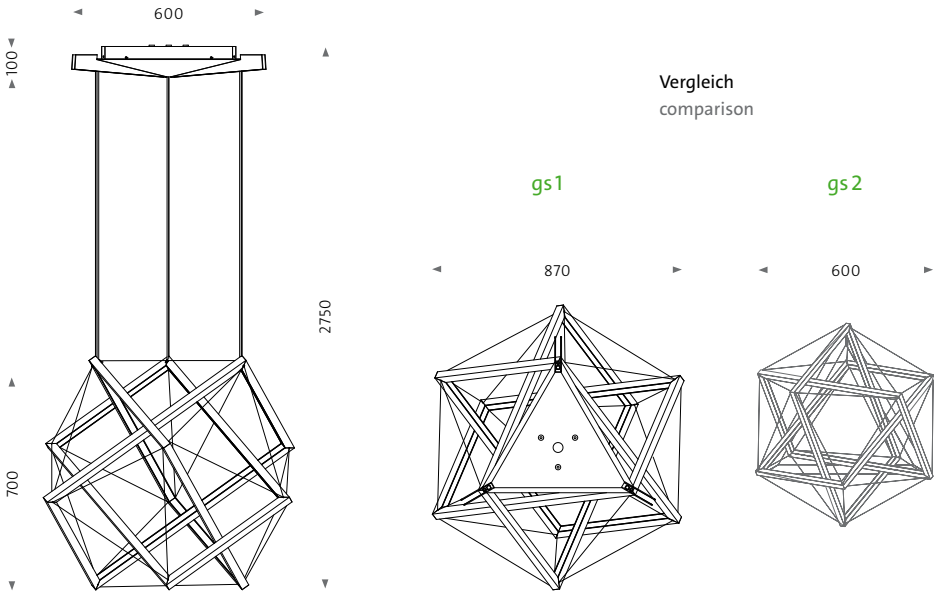
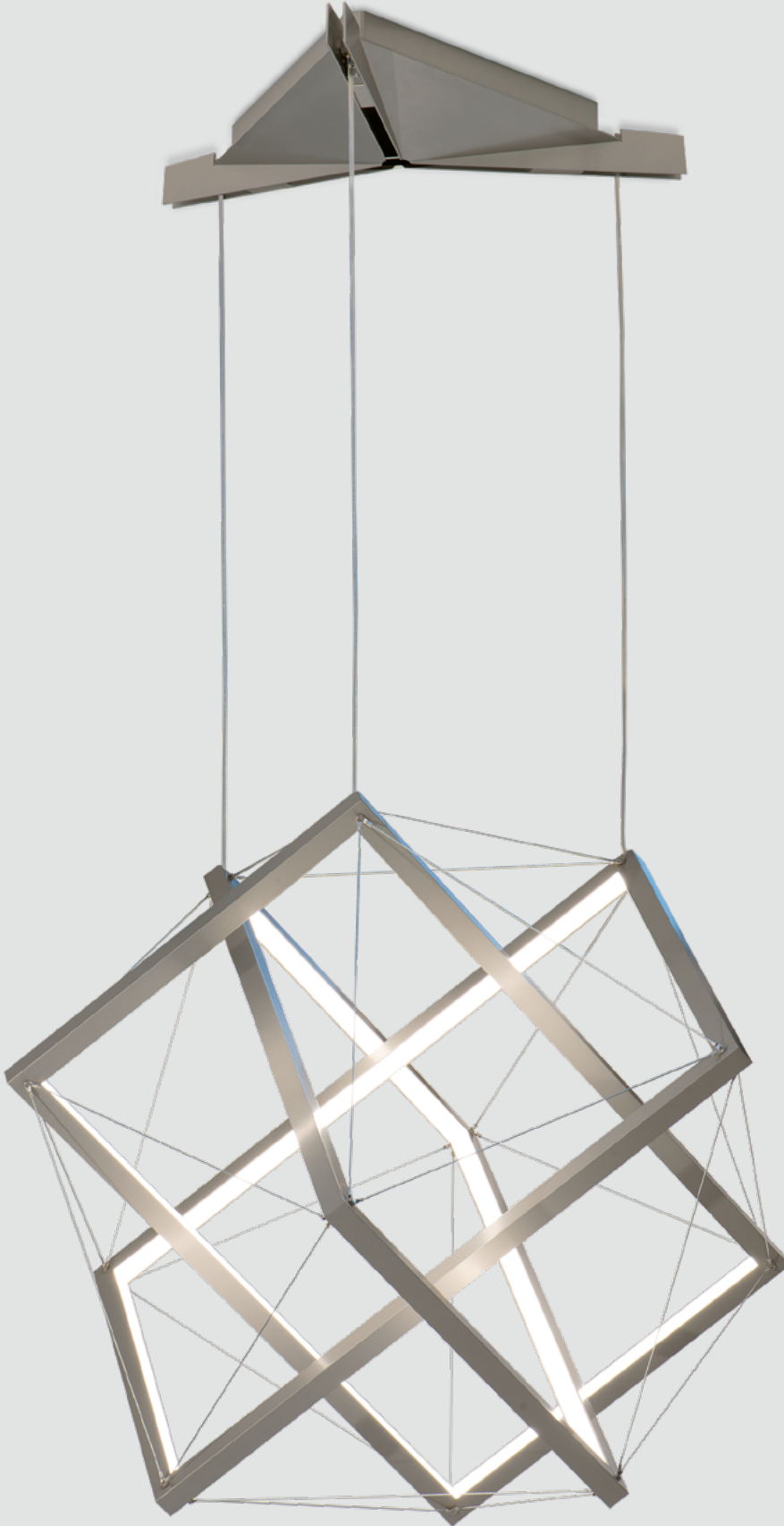

# goldener schnitt 2

Design: Lutz Köbele-Lipp

gs 2

Gehäuse Housing



LED: 49 W, 2700 K / 5760 lm, 3000 K / 5900 lm, Ra > 90 (typ. 92)

dimmbar

Gesamtpendellänge inklusive Leuchte: transparentes Kabel 2,00 m

LED: 49 W, 2700 K / 5760 lm, 3000 K / 5900 lm, Ra > 90 (typ. 92)

dimmbare

Pendant length including light: transparent cable 2.00 m

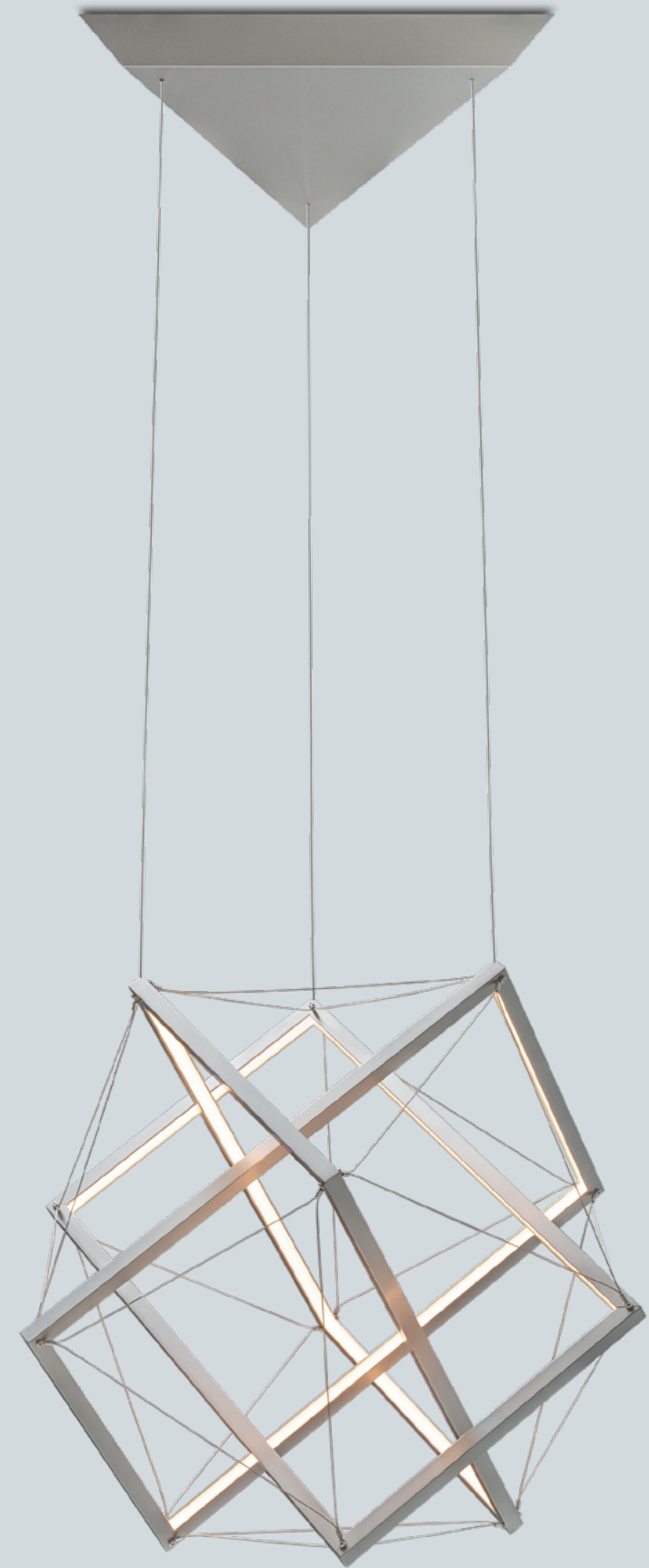
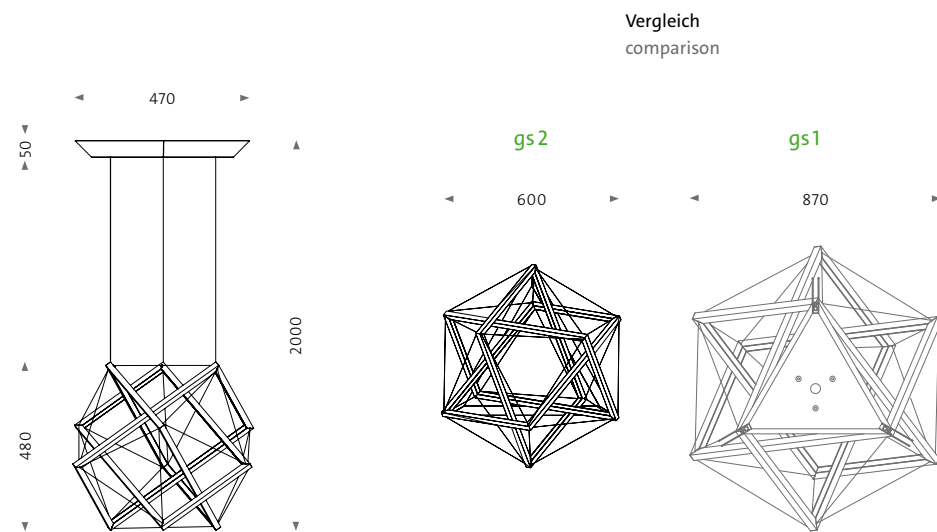

# havanna

Pendelleuchte mit mundgeblasenem Glaskörper  
Pendant light with mouth blown glass body

Design: Wilhelm Braun-Feldweg, 1959

ha 1  
ha 2  
ha 1d  
ha 2d

Gehäuse Housing



Fassung: E27, max. 100 W, exklusive Leuchtmittel

Gesamtpendellänge inklusive Leuchte: 2,00 m (ha 1) oder 1,90 m (ha 2) mit silbernen Textilkabel oder Drahtseilabhängung (d) mit transparentem Kabel exklusive Leuchte 2,50 m

Socket: E27, max. 100 W, bulb not included

Pendant length including light: 2.00 m (ha 1) or 1.90 m (ha 2) with silver textile cable or wire suspension (d) with transparent cable without light 2.50 m

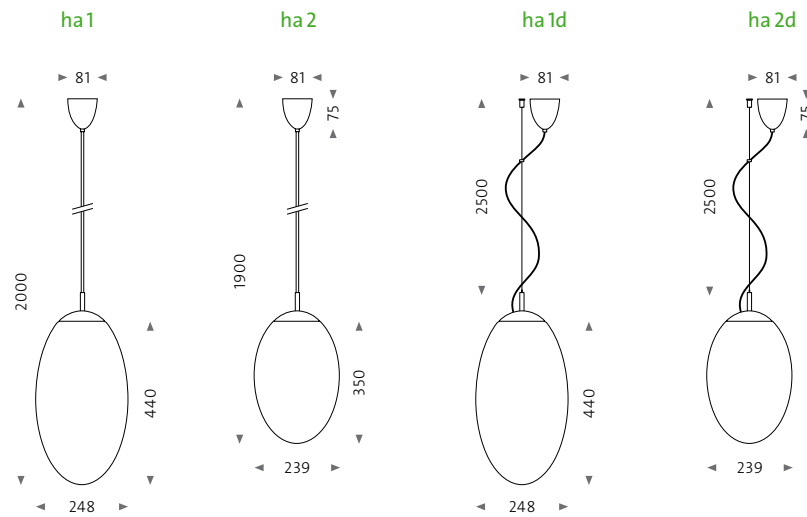



# madrid rund

Design: Isabel Hamm

ma 8rk  
ma 8rg

Glasvarianten Glass versions



ma 8rk: 42 individuelle Glashaken  
ma 8rg: 75 individuelle Glashaken  
Gesamtpendellänge inklusive Leuchte: 2,40 m (3 × Reutlinger® Drahtseile)  
ma 8rk: 42 individual glass hooks  
ma 8rg: 75 individual glass hooks  
Pendant length including light: 2.40 m (3 × Reutlinger® cables)



Foto: ma/wa



# madrid oval

Design: Isabel Hamm

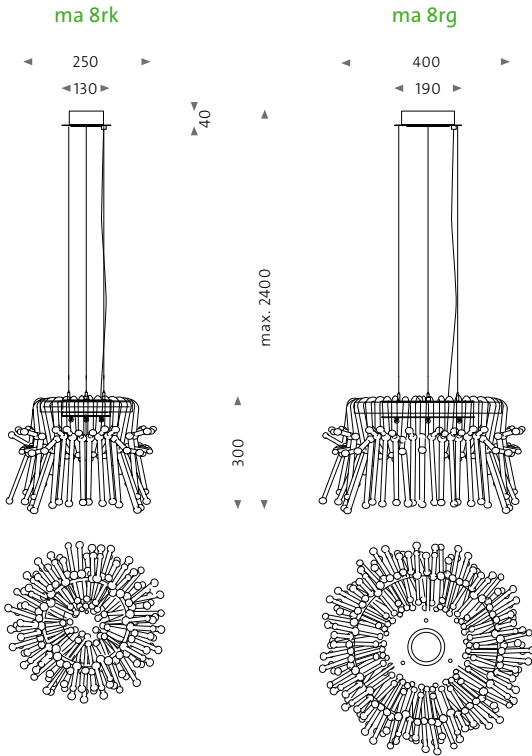
ma80

Glasvarianten Glass versions



- ma80-1200: 146 individuelle Glashaken (3 verschiedene Typen)
- ma80-1300: 165 individuelle Glashaken (3 verschiedene Typen) (ohne Abb.)
- ma80-1500: 184 individuelle Glashaken (3 verschiedene Typen)
- Gesamtpendellänge inklusive Leuchte: 2,40 m (4 × Reutlinger® Drahtseile)
- ma80-1200: 146 individual glass hooks (3 different types)
- ma80-1300: 165 individual glass hooks (3 different types) (not shown)
- ma80-1500: 184 individual glass hooks (3 different types)
- Pendant length including light: 2.40 m (4 × Reutlinger® cables)

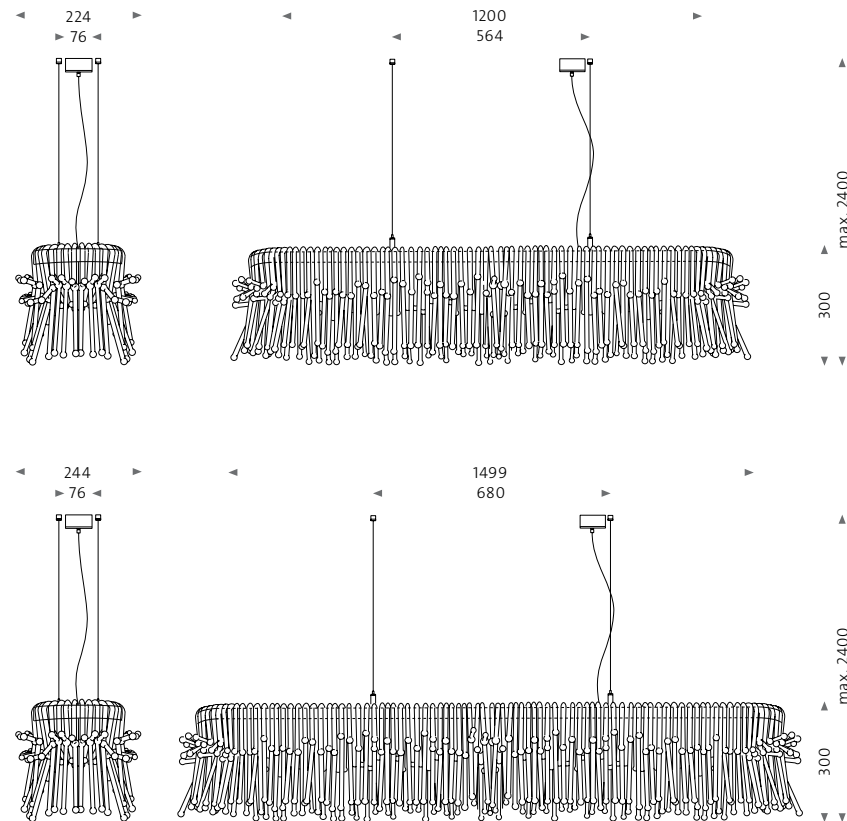

ma80-1200

ma80-1500

DESIGN PLUS  
powered by light+building





# mondello

Pendelleuchte mit mundgeblasenem Glaskörper  
Pendant light with mouth blown glass body

Design: Wilhelm Braun-Feldweg, 1959

mon1  
mon1d

Glasvarianten Glass versions



Fassung: E27, max. 100 W A60, LED-Retrofit möglich  
exklusive Leuchtmittel  
Gesamtpendellänge inklusive Leuchte: silbernes Textilkabel 1,90 m  
oder Drahtseilabhängung (d) mit transparentem Kabel  
exklusive Leuchte 2,50 m

Socket: E27, max. 100 W A60, LED-retrofit possible  
bulb not included

Pendant length including light: silver textile cable 1.90 m  
or wire suspension (d) with transparent cable  
without light 2.50 m

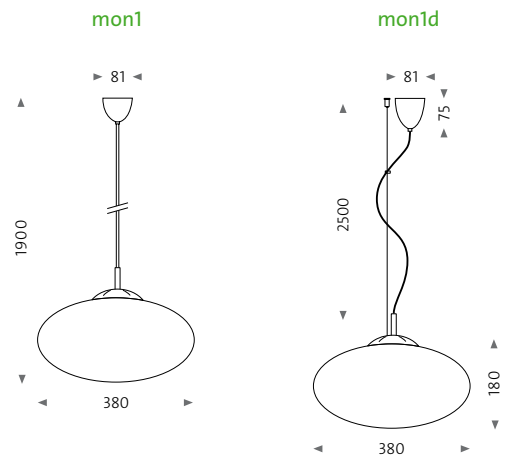

# ssymmank 1p / 4p

Design: Prof. Günter Ssymmank

sy1p  
sy4p

Gehäuse Housing



Fassung: E14, max. 40 W, exklusive Leuchtmittel  
 Gesamtpendellänge inklusive Leuchte sy1p: transparentes Kabel 2,10 m  
 Gesamtpendellänge inklusive Leuchte sy4p: transparentes Kabel 0,70 m  
 Socket: E14, max. 40 W, bulb not included  
 Pendant length including light sy1p: transparent cable 2.10 m  
 Pendant length including light sy4p: transparent cable 0.70 m

Blattelement Leaf element



sy4p

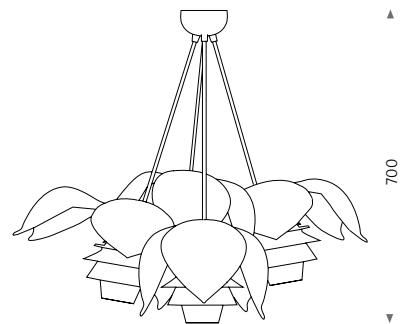

sy1p

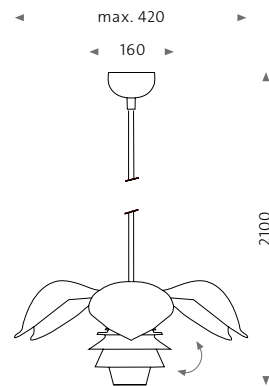

ssymmank-Stehleuchte  
 ab Seite 66  
 ssymmank floor lamp  
 from page 66

sy1p



sy4p



Foto: Maximilian Meisse

ssymmank sy1p; Sukhavati, Bad Saarow



# tokyo

Pendelleuchte mit mundgeblasenem Glaskörper  
Pendant light with mouth blown glass body

Braun-Feldweg-Edition  
Design: Wilhelm Braun Feldweg, 1962

to1

Gehäuse Housing



Fassung: E27, max. 60 W, exklusive Leuchtmittel  
Gesamtpendellänge inklusive Leuchte: transparentes Kabel 2,50 m  
Socket: E27, max. 60 W, bulb not included  
Pendant length including light: transparent cable 2.50 m

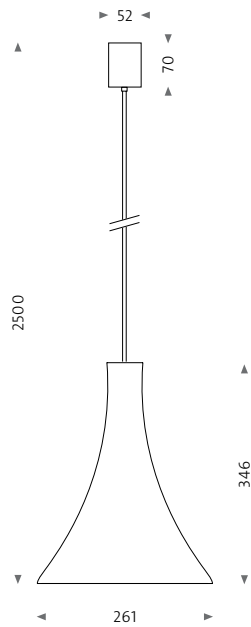



Wand- und  
Deckenleuchten  
*Wall and  
ceiling lights*



# Getreu dem Motto »klein, aber oho«

Diese Rubrik umfasst dekorative Einzelleuchten von überschaubarer Größe, variabler Anwendung und einfacher Handhabung. Sie lassen sich kreativ gruppieren und schmücken selbst den kleinsten Raum.

Ob simple Fassungsverkleidung etna, moderne Interpretation tesechzehn oder funktionale Neuentwicklung jo, mawa spart auch im Kleinen nicht an Wertigkeit.

Blattvergoldete Oberflächen sind ebenso erhältlich wie das »weiße Gold« der Königlichen Porzellan-Manufaktur zu Berlin.

Sicher finden auch Sie ein Plätzchen für eine dieser praktischen Alltagsleuchten mit dem gewissen Etwas.



Foto: mawa

# True to the motto “small but beautiful”

This category includes decorative single luminaires of manageable size, variable application and easy handling. They can be grouped creatively and decorate even the smallest room.

Whether it is the socket covering etna, the modern interpretation tesechzehn or the functional new development jo, mawa does not compromise on value even in the smallest scale.

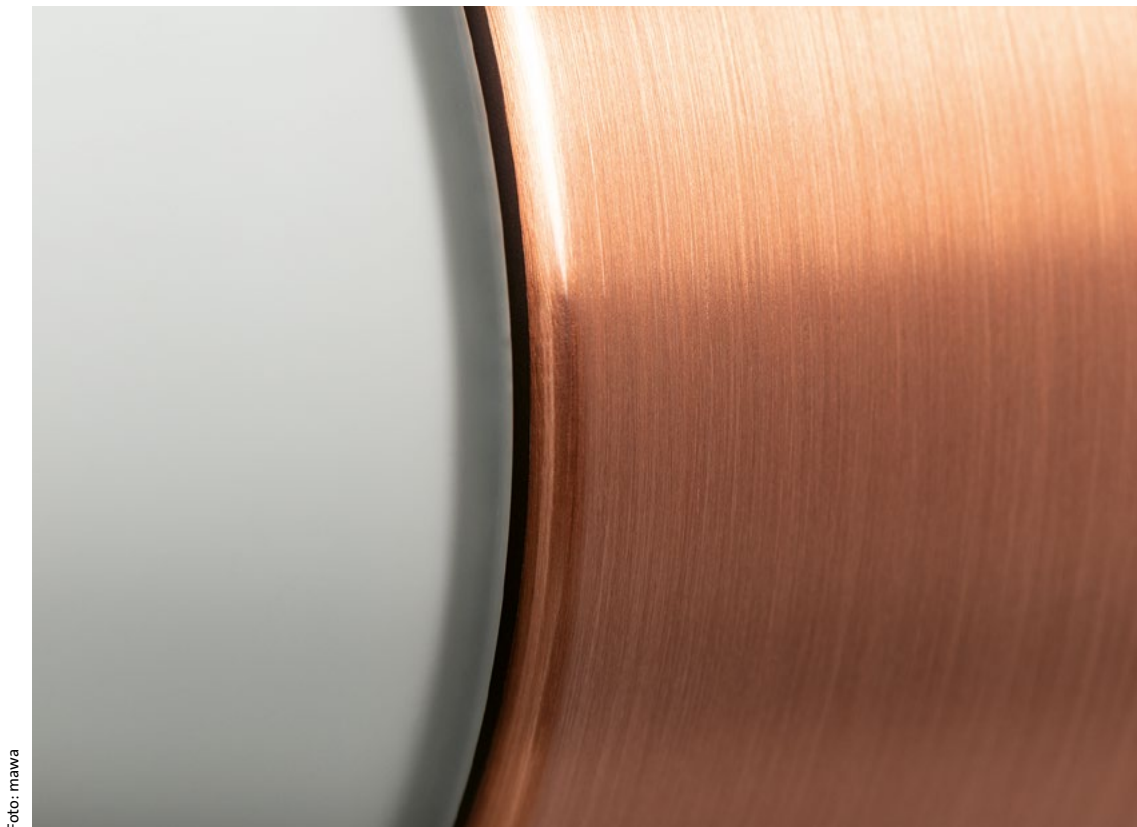
Gold-leaf surfaces are available as well as “white gold” made by Königliche Porzellan-Manufaktur Berlin.

Surely you will find a place for one of these practical everyday lights with that certain je ne sais quoi.



Foto: mawa

# jo / jo IP44

Design: Martin Wallroth

IP44



jo-om  
jo-om-IP44

Gehäuse jo-om Housing jo-om



Gehäuse jo-om-IP44 Housing jo-om-IP44



Fassung: E27, max. 60 W

inklusive Leuchtmittel: E27, G45, 2700 K / 806 lm, 6 W

dimmbar

Socket: E27, max. 60 W

bulb included: E27, G45, 2700 K / 806 lm, 6 W

dimmmable

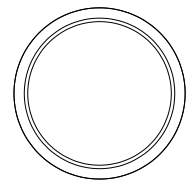

113

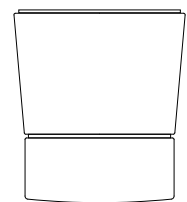

81

43

jo-om



jo-om-IP44





# maggy 1

Design: Kressel + Schelle

## mag1

Gehäuse Housing



HV LED: 4W, 2700K/450lm, Ra >80 (typ. 85)

schaltbar

Kabel inklusive Leuchte: Textilkabel 2,50 m

HV LED: 4W, 2700K/450lm, Ra >80 (typ. 85)

switchable

Cable including light: textile cable 2.50 m

Kabel Cable

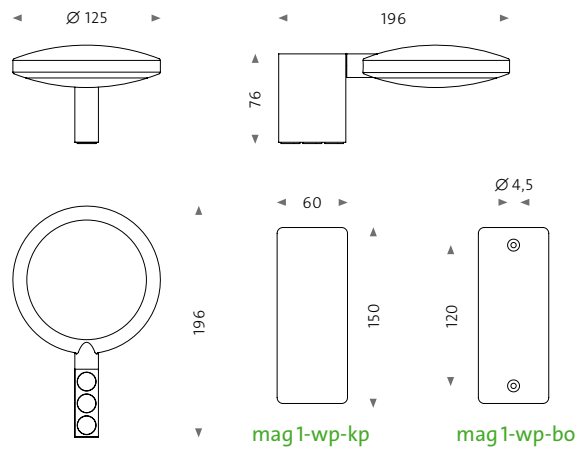

# maggy 3

Design: Kressel + Schelle, mawa

## mag3

Gehäuse Housing



HV LED: 4W, 2700K/450lm, Ra >80 (typ. 85)

schaltbar

HV LED: 4W, 2700K/450lm, Ra >80 (typ. 85)

switchable

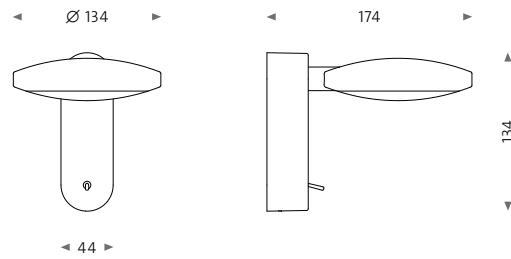



# maggy 4

Design: Kressel + Schelle, mawa

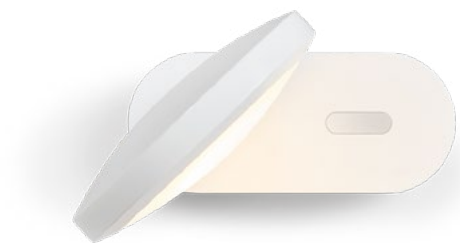

## mag 4

Gehäuse Housing



LED: 11 W, 2700K/800lm, Ra > 90 (typ. 92)  
dimmbar über Tastschalter mit Memory-Funktion  
LED: 11 W, 2700K/800lm, Ra > 90 (typ. 92)  
dimmable via push button with memory function

Taster Button



Foto: Leon Koppelow



# tesechzehn

Design: Dirk Salewski, mawa

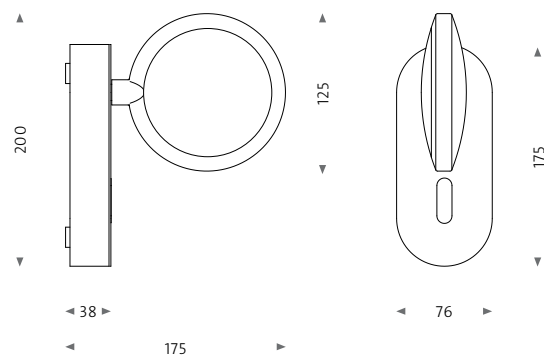
ts-600  
ts-1200

Gehäuse Housing



LED: ts-600: 24 W, 2700 K / 2958 lm, 3000 K / 3106 lm  
Ra > 90 (typ. 92)

ts-1200: 48 W, 2700 K / 5916 lm, 3000 K / 6212 lm  
Ra > 90 (typ. 92)

dimmbar

LED: ts-600: 24 W, 2700 K / 2958 lm, 3000 K / 3106 lm  
Ra > 90 (typ. 92)

ts-1200: 48 W, 2700 K / 5916 lm, 3000 K / 6212 lm  
Ra > 90 (typ. 92)

dimmmable

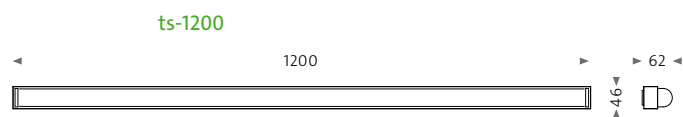
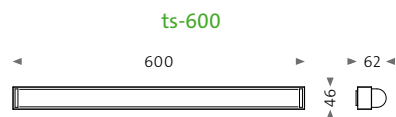

ts-600



ts-1200





# eintopf / eintopf KPM-Edition



eintopf KPM-Edition mit feinstem KPM-Porzellan  
in handwerklicher Präzision  
eintopf KPM-Edition with finest KPM porcelain  
in handcrafted precision

Design: Martin Wallroth

et1  
et1-kpm

Gehäuse et1 Housing et1



Gehäuse et1-kpm Housing et1-kpm



Fassung: E27, max. 60 W, exklusive Leuchtmittel  
Socket: E27, max. 60 W, bulb not included

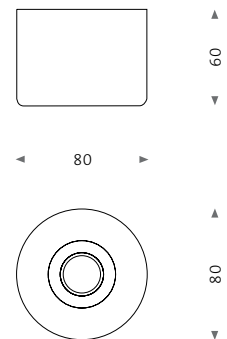

et1



et1-kpm



Architektur: Thomas Kröger, Foto: Thomas Heilmann



eintopf et1-kpm; Landhaus Fergitz, Uckermark  
eintopf et1-kpm; Country house Fergitz, Uckermark

# eintopf einbau

Design: Martin Wallroth

et1-eb

Gehäuse Housing



Fassung: E27, max. 60 W  
exklusive Leuchtmittel  
Socket: E27, max. 60 W  
bulb not included

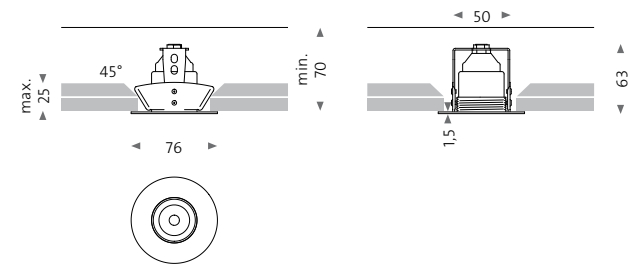

Deckenausschnitt: Ø 70 mm  
ceiling cut-out: Ø 70 mm









# etna / etna KPM-Edition



etna KPM-Edition mit feinstem KPM-Porzellan  
in handwerklicher Präzision  
etna KPM-Edition with finest KPM porcelain  
in handcrafted precision

Design: Martin Wallroth

et2  
et2-kpm

Gehäuse et2 Housing et2



Gehäuse et2-kpm Housing et2-kpm



Fassung: E27, max. 60 W, exklusive Leuchtmittel  
Socket: E27, max. 60 W, bulb not included

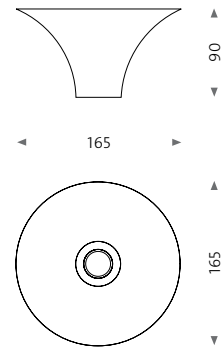

et2



et2-kpm





# linestra 7 / 7b / 8

Design: Martin Wallroth

li7  
li7b  
li8

Gehäuse Housing



Fassung: li7 S14d, max. 60 W, exklusive Leuchtmittel

li7b S14d, max. 60 W, exklusive Leuchtmittel

li8 S14s, max. 60 W, exklusive Leuchtmittel

Socket: li7 S14d, max. 60 W, illuminant not included

li7b S14d, max. 60 W, illuminant not included

li8 S14s, max. 60 W, illuminant not included

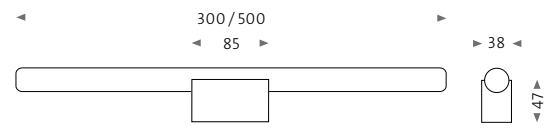

li7

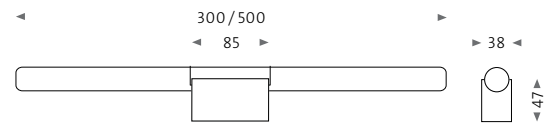

li7b

li7b kann mit Klammer als  
Deckenleuchte eingesetzt werden  
li7b can be used as a ceiling light  
with clamp

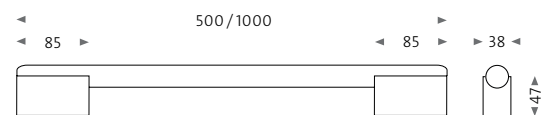

li8



li7



li7b



li8



# stuttgart eb / ab

Design: Michele Rami

sg1-eb  
sg1-ab

Gehäuse Housing



Fassung: E27, max. 40 W, exklusive Leuchtmittel  
Socket: E27, max. 40 W, bulb not included

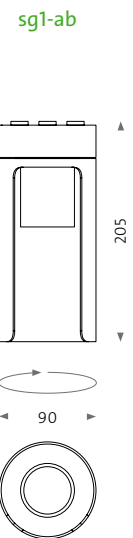
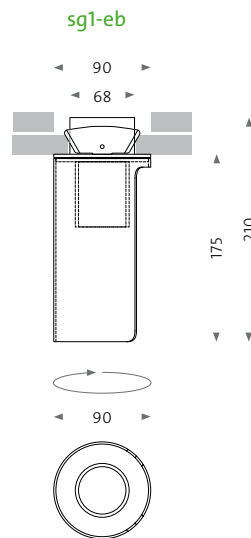

frei drehbar in beide Richtungen  
freely rotatable in both directions

sg1-eb



sg1-ab



Foto: maWa



# paul

Design: Berliner Klassizismus

pa1

Gehäuse Housing



Fassung: E27, max. 60 W, exklusive Leuchtmittel  
Socket: E27, max. 60 W, bulb not included

Tubus Tube

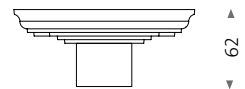

62

150

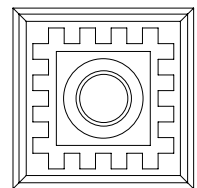

150



Wand- und Deckenleuchten



Architektur: Kahlfeldt Architekten, Berlin; Foto: Stefan Müller

paul pa1

# paula / paula KPM-Edition



paula KPM-Edition mit feinstem KPM-Porzellan  
in handwerklicher Präzision  
paula KPM-Edition with finest KPM porcelain  
in handcrafted precision

Design: Berliner Klassizismus

pa 2  
pa 2-kpm

Gehäuse Housing



Fassung: E27, max. 60 W, exklusive Leuchtmittel  
Socket: E27, max. 60 W, bulb not included

Tubus pa 2 Tube pa 2



Tubus pa 2-kpm Tube pa 2-kpm

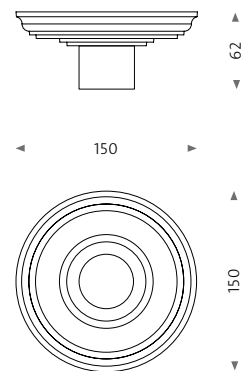

pa 2



pa 2-kpm





# britz 1 / 2

Braun-Feldweg-Edition

Design: Wilhelm Braun-Feldweg

**bri1**  
**bri2**

Gehäuse Housing



Fassung: bri1 E14, max. 60 W Kerzenlampe (C35)

exklusive Leuchtmittel

bri2 E14, max. 60 W Tropfenlampe (D45)

exklusive Leuchtmittel

Socket: bri1 E14, max. 60 W candle lamp (C35)

bulb not included

bri2 E14, max. 60 W drop lamp (D45)

bulbs not included

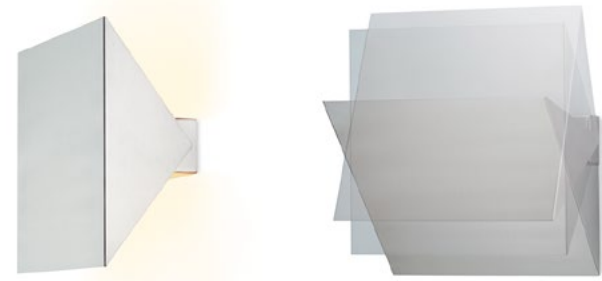

**bri2**

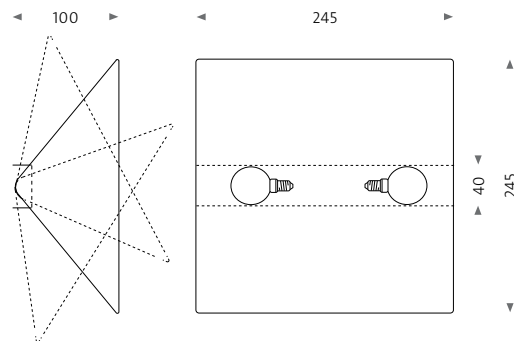

**bri1**

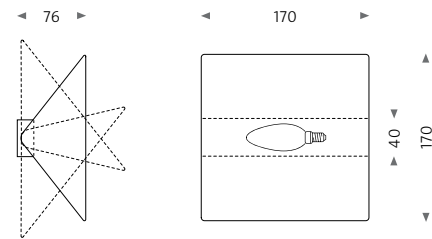

**br1**



**br2**



# tegel 2 / 6 / 7

Braun-Feldweg-Edition

Design: Wilhelm Braun-Feldweg

tegel2  
tegel6  
tegel7

Gehäuse teg2 Housing teg2



Gehäuse teg6 Housing teg6



Gehäuse teg7 Housing teg7



Fassung: teg2 E14, max. 2 × 40 W, exklusive Leuchtmittel

tegel6 E27, 2 × 60 W, exklusive Leuchtmittel

tegel7 LED 10,5 W, 3000 K / 1300 lm

dimmbar

Socket: teg2 E14, max. 2 × 40 W, bulbs not included

tegel6 E27, 2 × 60 W, bulbs not included

tegel7 LED 10.5 W, 3000 K / 1300 lm

dimmmable

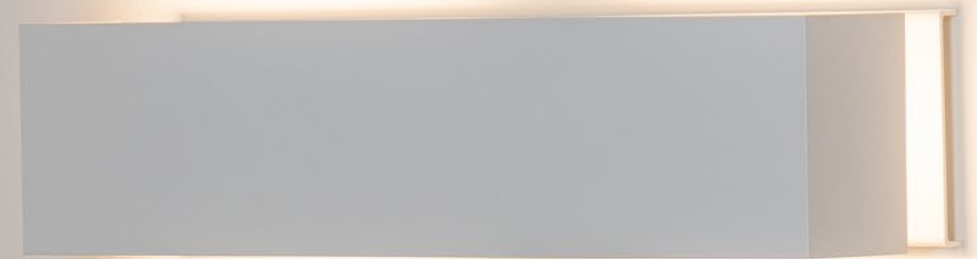

tegel2



tegel6



tegel7



tegel2

tegel6

tegel7

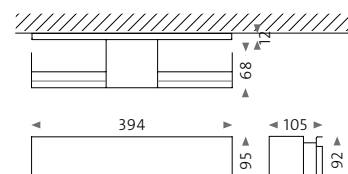
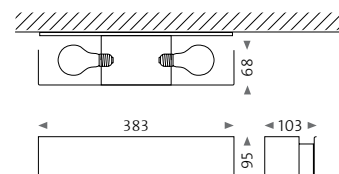
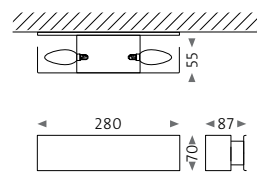



# 111er

Design: Martin Wallroth

## 111er-1r

Gehäuse Housing



Produktvarianten

GU10: GU10-Fassung / 230V / max. 75 W

HV LED: mit Anschlussklemme für LED / 230V

LED: mit Betriebsgerät und Anschlussklemme für LED bis 21 W / 500 mA

alle Varianten exklusive Leuchtmittel

dimmbar (abhängig vom Leuchtmittel)

Product versions

GU10: with GU10 socket / 230V / max. 75 W

HV LED: with connection terminal for LED / 230V

LED: with control gear and connection terminal for LED up to 21 W / 500 mA

all versions illuminant not included

dimmable (depending on illuminant)

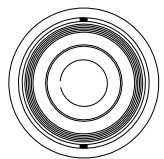

150  
115

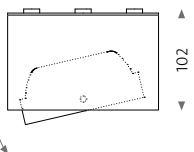

25°

180



Innenarchitektur Design: Gisbert Pöpple, Foto: Wolfgang Stahr

111er-1r



# d28-eb-r / d28-eb-rs

Design: Lars Dinter, mawa



d28-eb-r  
d28-eb-rs

Gehäuse Housing



LED: 5 W, 2700 K / 400 lm, Ra > 80, exklusive Betriebsgerät  
 dimmbar (abhängig vom Betriebsgerät)  
 LED: 5 W, 2700 K / 400 lm, Ra > 80, control gear not included  
 dimmable (depending on control gear)

Reflektor innen Reflector inside



d28-eb-r

d28-eb-rs

+/-15°

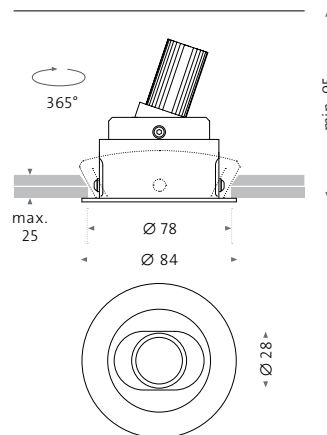
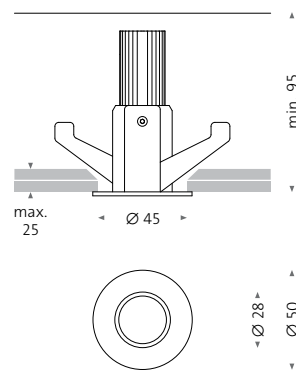

Deckenausschnitt: Ø 45 mm  
 (bei 25 mm Deckenstärke muss die obere  
 Rigipsplatte angeschrägt werden)  
 ceiling cut-out: Ø 45 mm  
 (with 25 mm ceiling thickness, the upper  
 plasterboard must be beveled)

Deckenausschnitt: Ø 70–78 mm  
 ceiling cut-out: Ø 70–78 mm

d28-eb-r



d28-eb-rs



Foto: Stefan Wolf Lucks

d28-eb-r; Waldkliniken Eisenberg



# warnemünde 23 / 33 / 63

IP54

Design: Martin Wallroth

wm23  
wm33  
wm63

Gehäuse Housing



LED: 11 W, 2700K/800lm, 3000K/850lm, Ra > 90  
dimmbar  
LED: 11 W, 2700K/800lm, 3000K/850lm, Ra > 90  
dimmable



wm23-G2

wm33-G2

wm63-G2

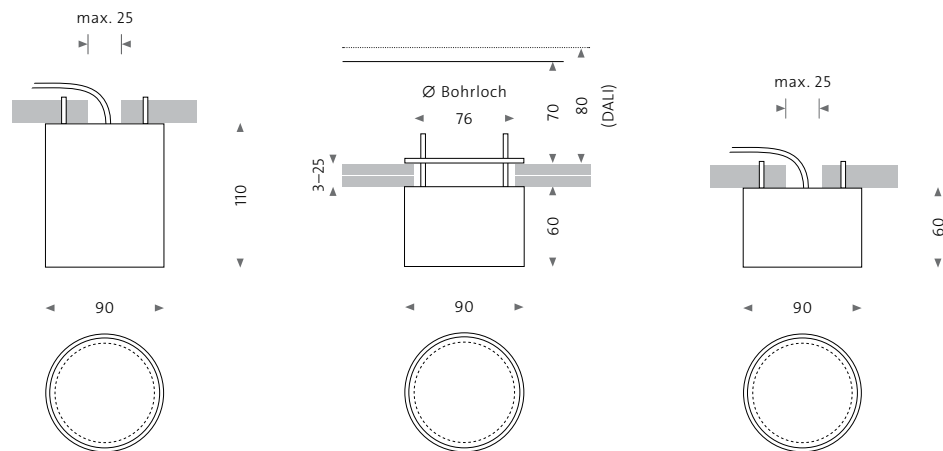

wm23



wm33 / wm63



Foto: mawa



# wi4-eb-1r-dl-IP44

IP44

Wand- und Deckenleuchten

wittenberg 4.0 Serie

Design: Martin Wallroth

## wi4-eb-1r-dl-IP44

Gehäuse Housing



LED: 12,7W, 2700K/1100lm, 3000K/1200lm, 4000K/1350lm

Ra > 90 (typ. 92), exklusive Betriebsgerät

dimmbar (abhängig vom Betriebsgerät)

LED: 12.7W, 2700K/1100lm, 3000K/1200lm, 4000K/1350lm

Ra > 90 (typ. 92), control gear not included

dimmable (depending on control gear)

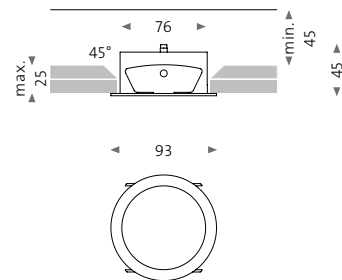

Deckenausschnitt: Ø 80 mm  
(bei 25 mm Deckenstärke muss die obere  
Trockenbauplatte angeschrägt werden)  
ceiling cut-out: Ø 80 mm  
(with 25 mm ceiling thickness, the upper  
plasterboard must be beveled)



Focus Open 2019  
Special Mention



Foto: ma/wa

wittenberg 4.0 wi4-eb-1r-dl-IP44



# wi4-ab-1r-dl-IP54

IP54

wittenberg 4.0 Serie

Design: Daniel Frey

## wi4-ab-1r-dl-IP54

Gehäuse Housing



LED: 10W, 2700K/700lm, 3000K/800lm, 4000K/900lm

Ra > 90 (typ. 92), inklusive Betriebsgerät

dimmbar

LED: 10W, 2700K/700lm, 3000K/800lm, 4000K/900lm

Ra > 90 (typ. 92), control gear included

dimmmable



Foto: maWa



»Alles kommt auf die Beleuchtung an.«

*“It all comes down to lighting.”*

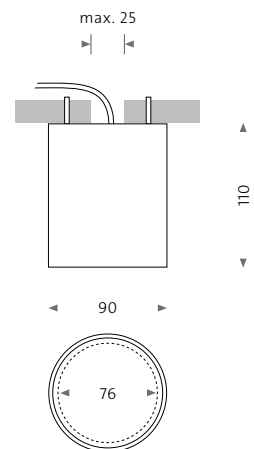
Theodor Fontane





Impressum *Imprint*

mawa design  
Licht- und Wohnideen GmbH

Member of the **PROLED GROUP**

Verwaltung *Headquarter*  
Neu-Langerwisch 36  
14552 Michendorf  
Germany

Produktion *Production*  
Ebereschenring 12–13  
14554 Seddiner See  
Germany

Gestaltung *Design*  
mawa  
weissbunt, design und kontext

Druck *Print*  
KOPA, Kaunas

Technische Änderungen  
und Irrtümer vorbehalten.  
*Subject to technical  
modifications and error.*

[www.mawa-design.de](http://www.mawa-design.de)

WEEE-Reg.-Nr. DE 945 963 57

Auflage *Edition*  
03/2023

»Alles kommt auf die Beleuchtung an.«

Zitat Theodor Fontane



mawa®

Made in Brandenburg  
[mawa-design.de](http://mawa-design.de)